

زبانِ تصویر

یک

«استاد کامران»
دانشگاه خوارزمی





تمرینات اجرایی

پارمیدا محبی

۴



قطه

اثر اصلی



رسم طرح کلی

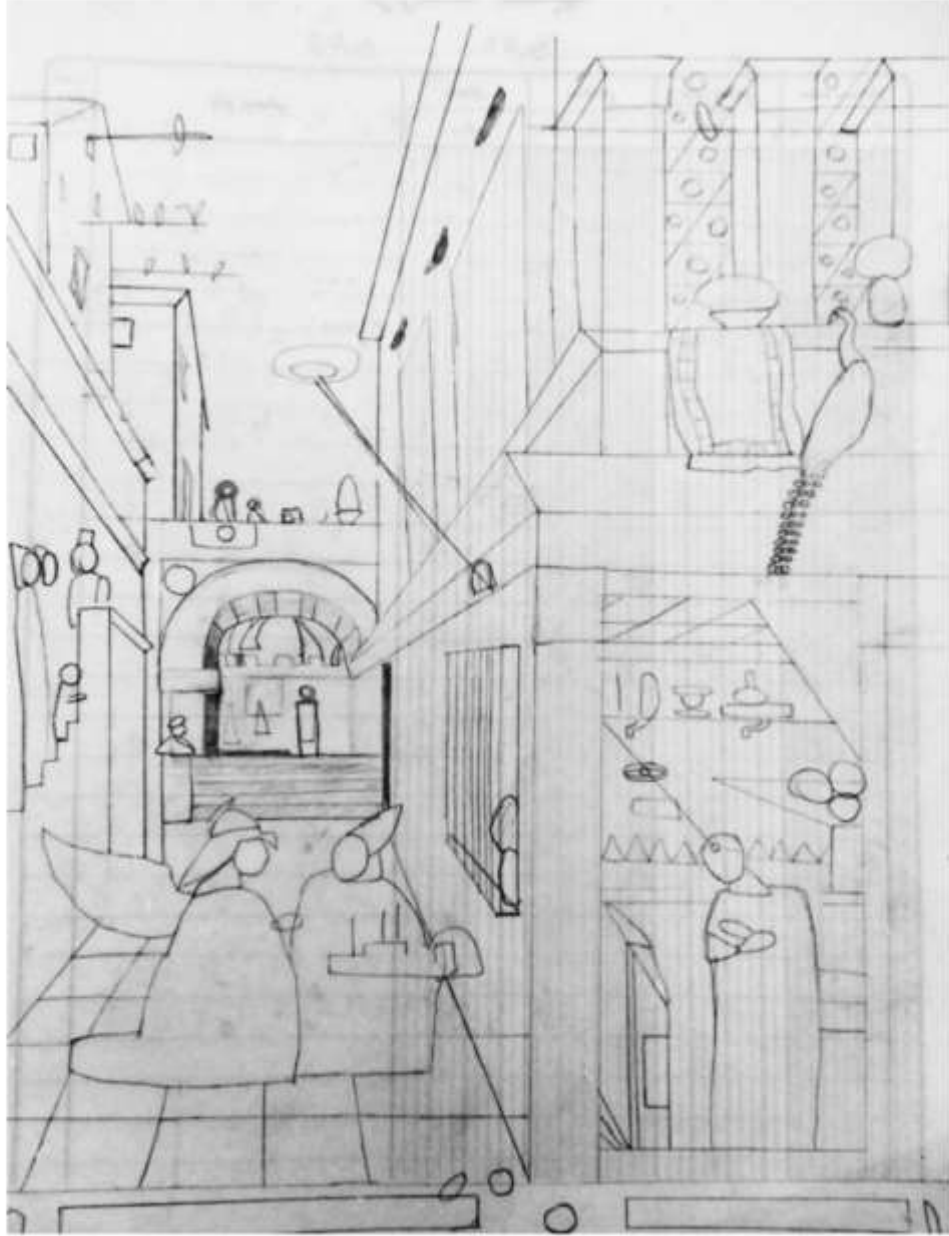

شناسایی نقاط

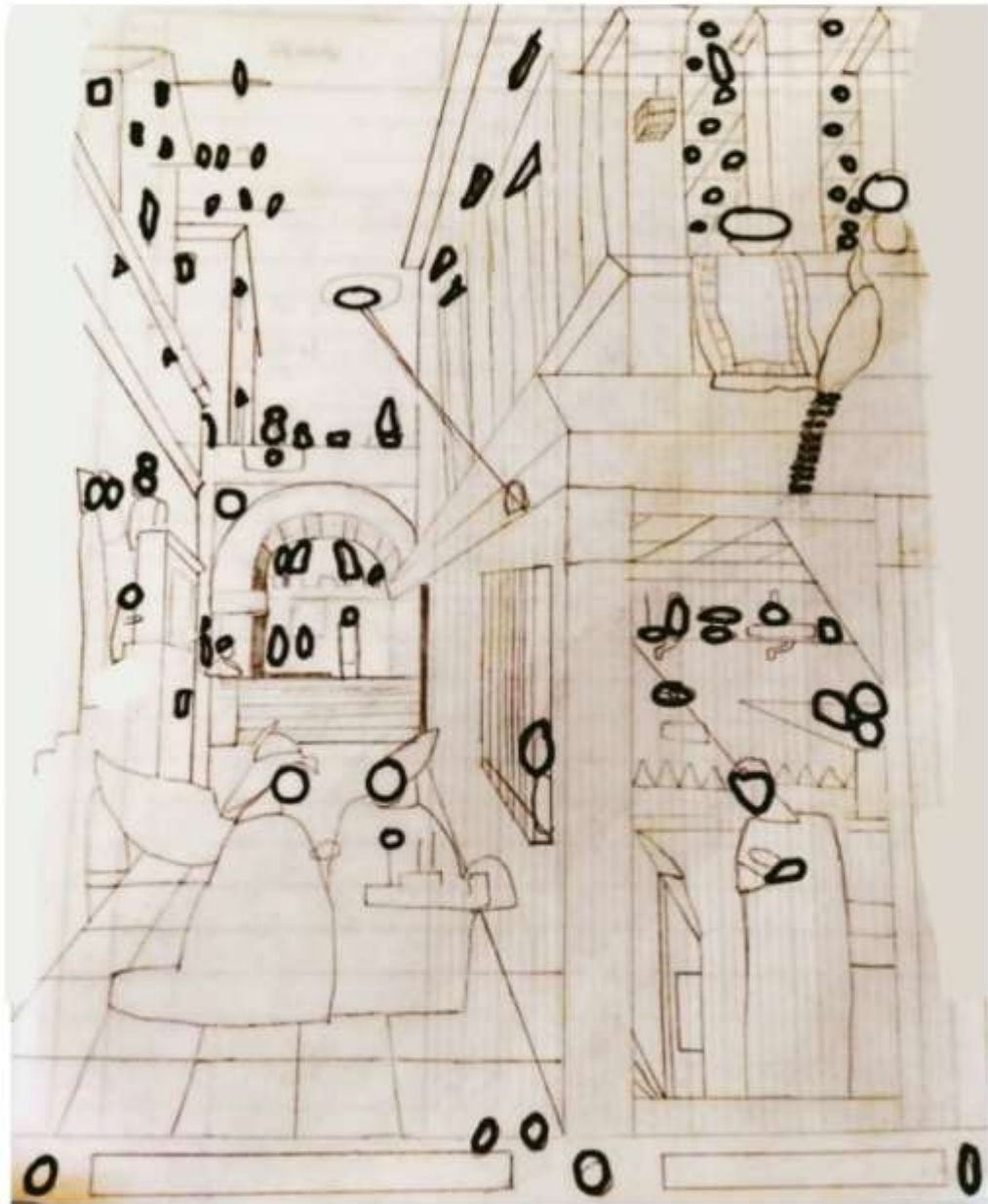

اثر اصلی



رسم طرح اوليه

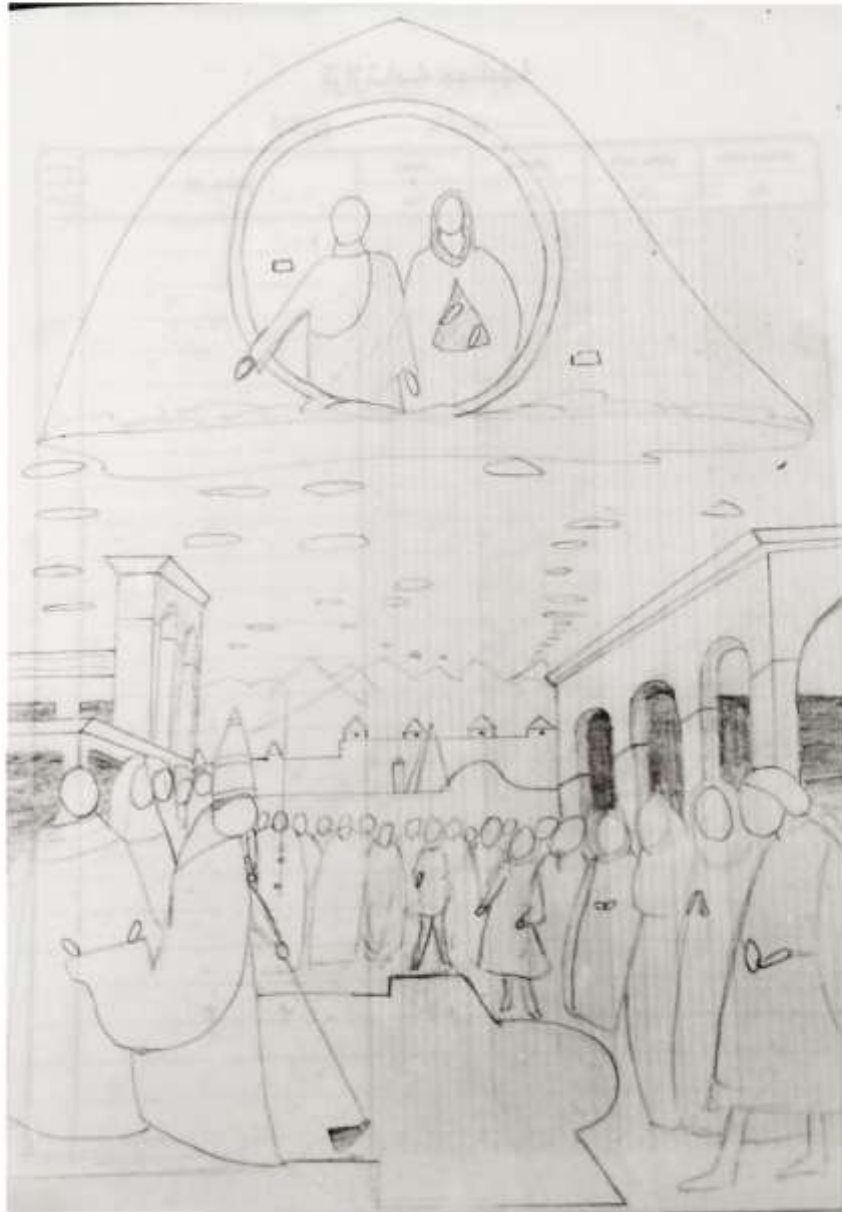

شناسایی نقاط

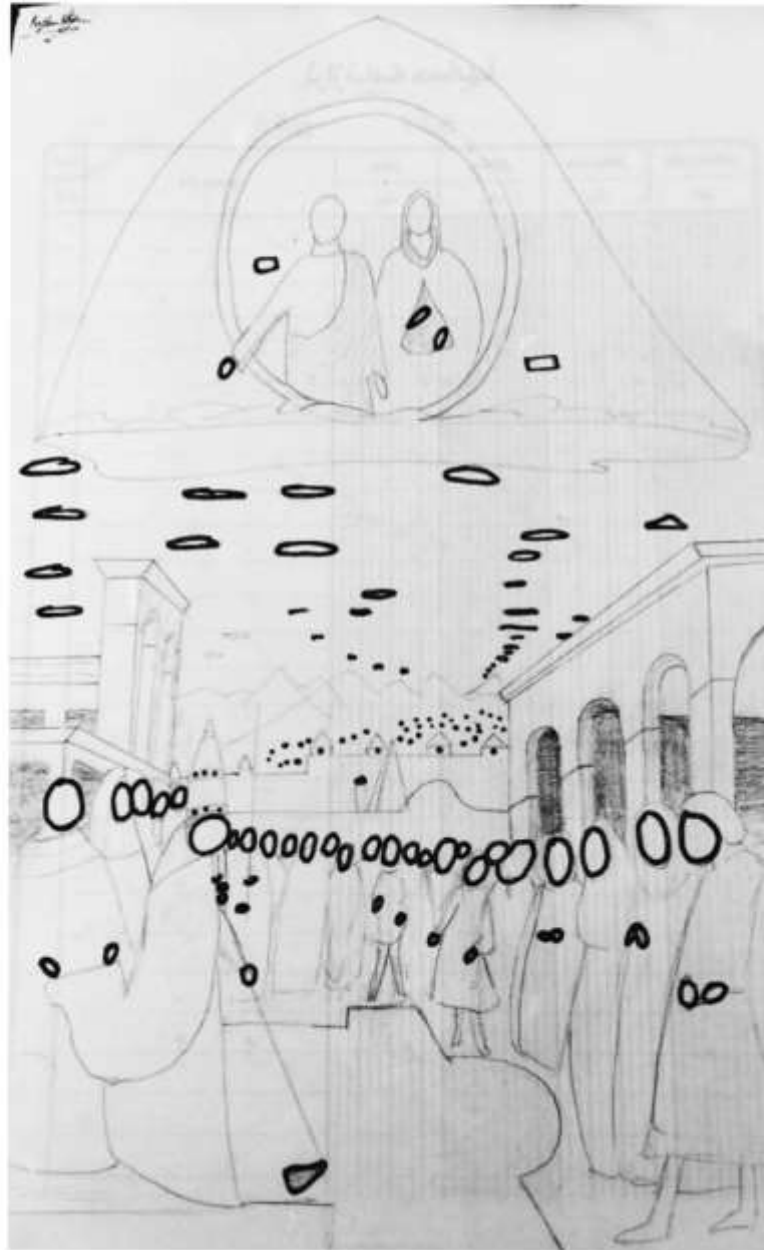

اثر اصلی



سنگ های کنار راه تقاطعی اند که به سوی خط شدن می روند

جعبه های وسط راه و بالای تابلوی انتهایی فقط نقطه اند.

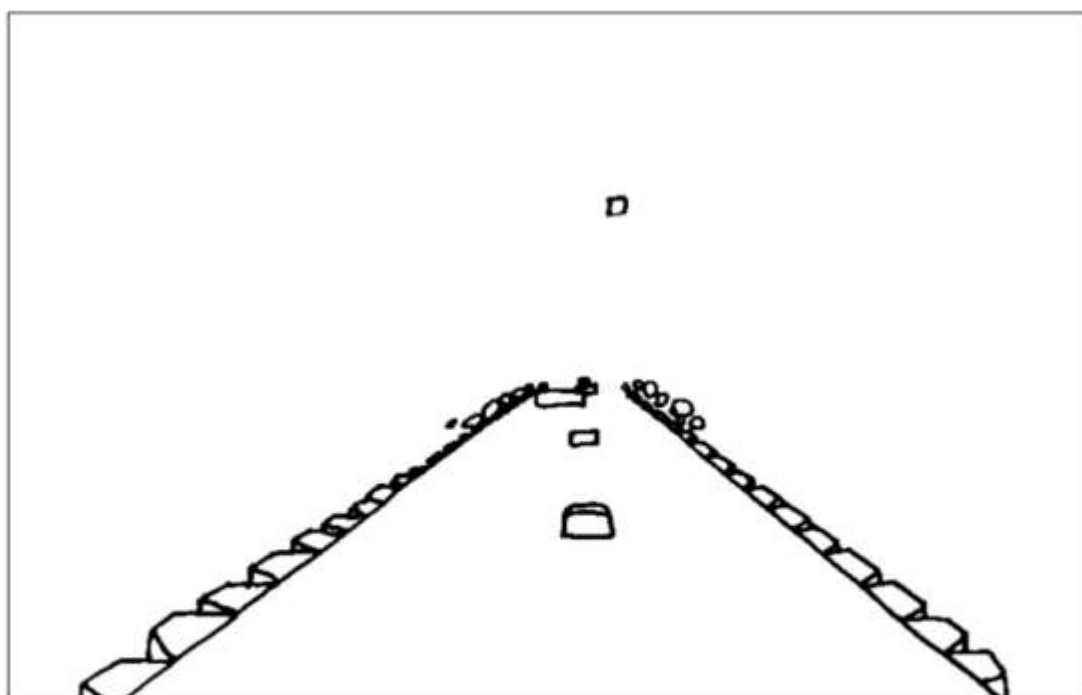

اثر اصلی



تبدیل نقاشی به نقطه





b _____ *j*

اثر اصلی



تبدیل عکس به خط



نقاشی با خط

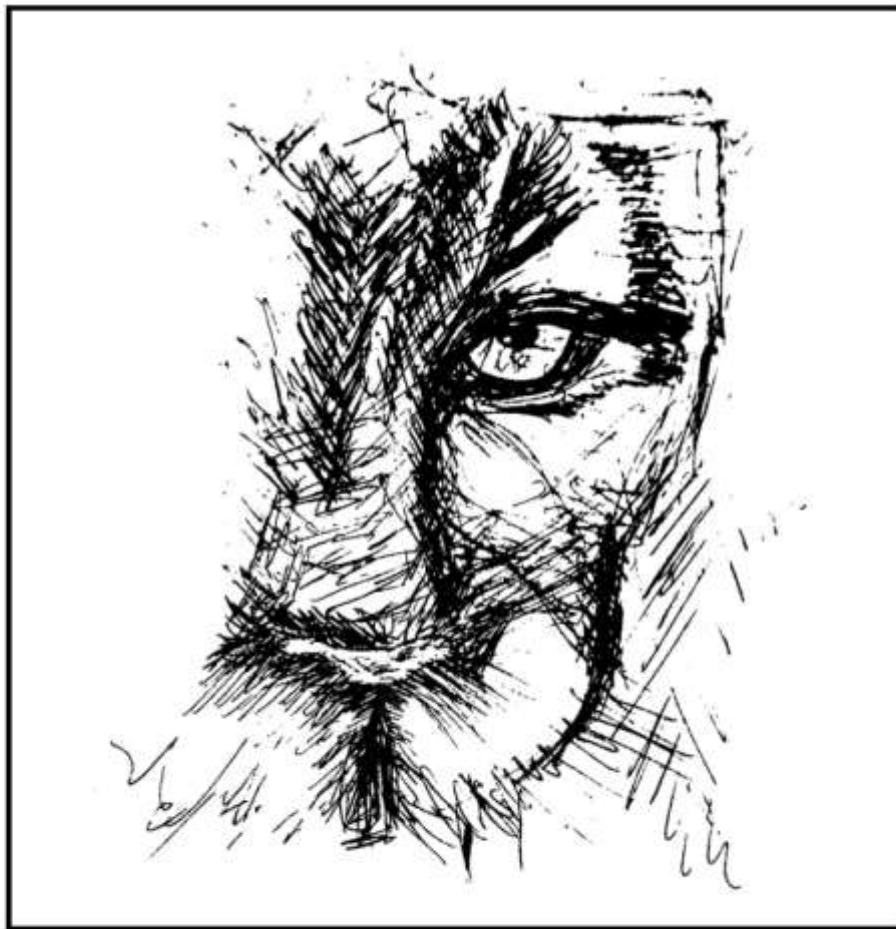

نقاشی با خط



نقاشی با خط





نُقْطَةٌ وَ نَخْطُ

نقاشی با خط و نقطه



نقاشی با نقطه و خط



کاربرد خط و نقطه در بخیه دوزی،
پولک دوزی و تکه دوزی



کاربرد خط و نقطه در بخیه دوزی،
پولک دوزی و تکه دوزی

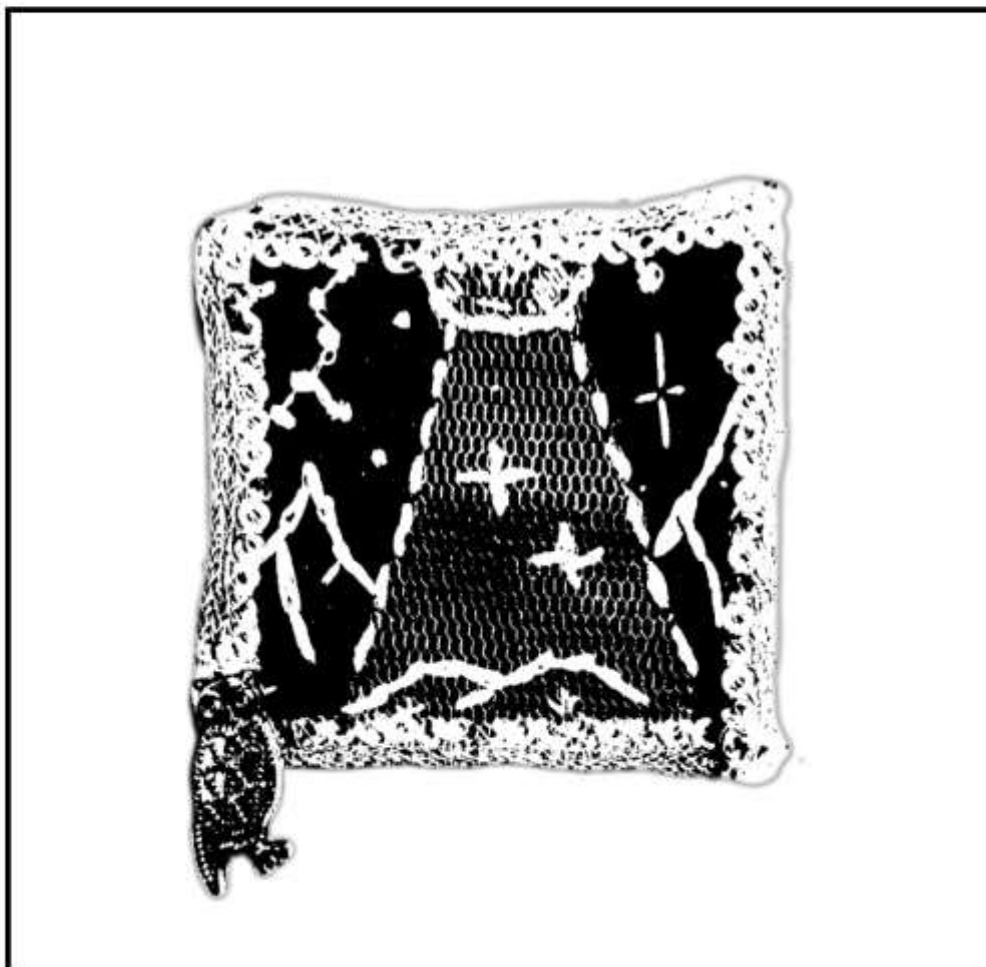

تَرکِیب



بَندِ دِی

مستطیل

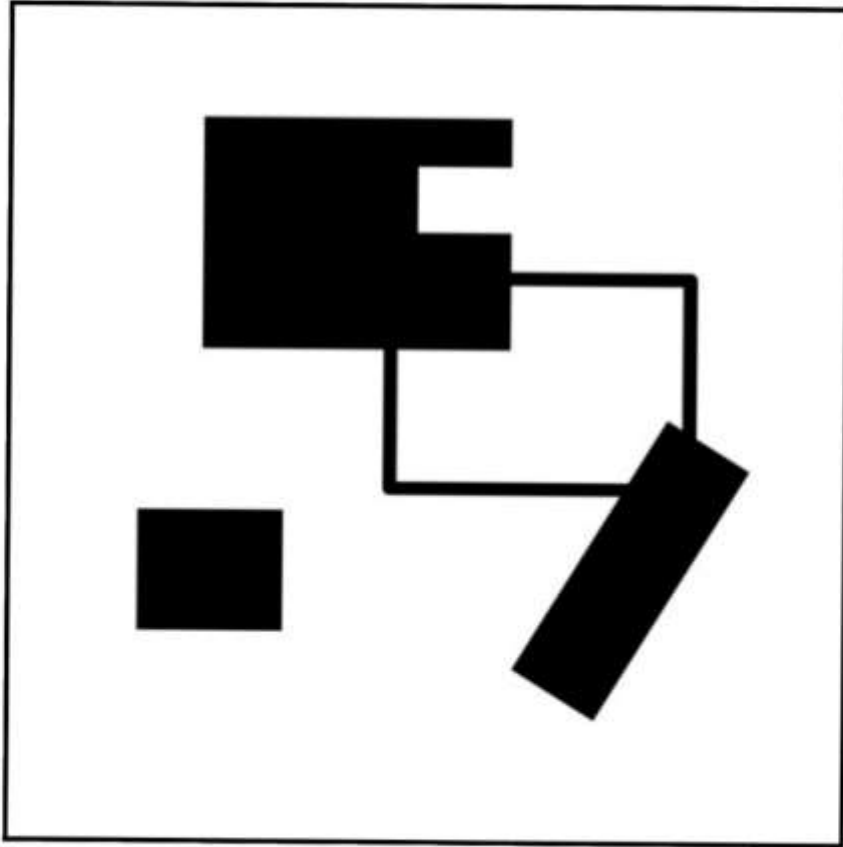

مستطیل

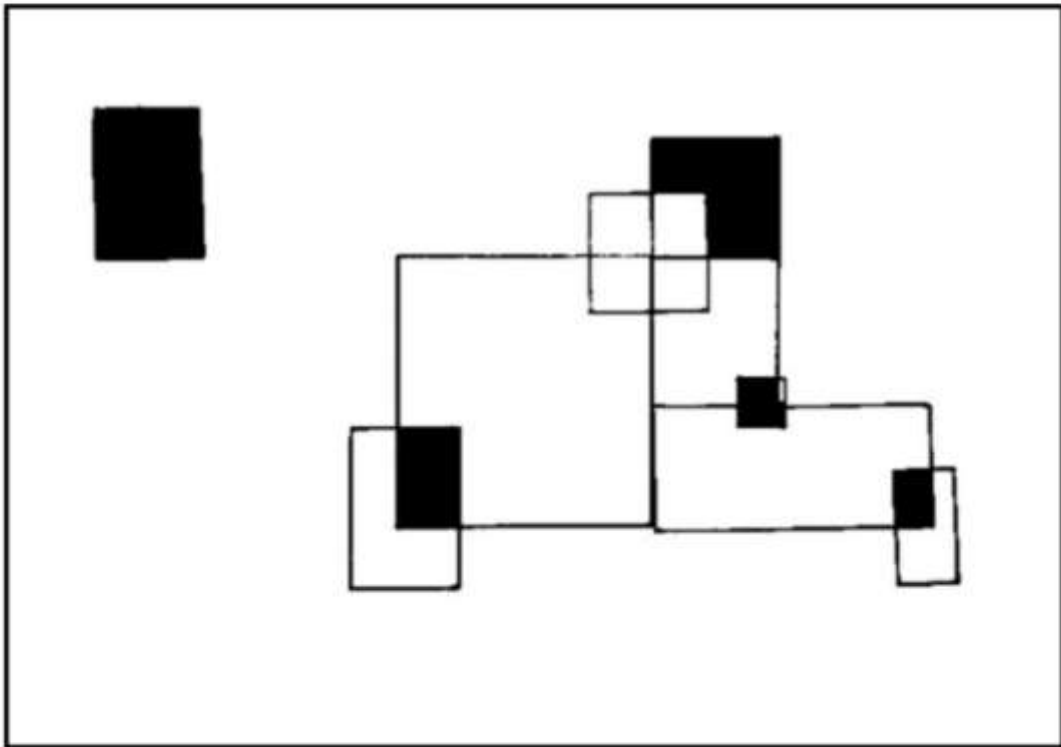

مثلث

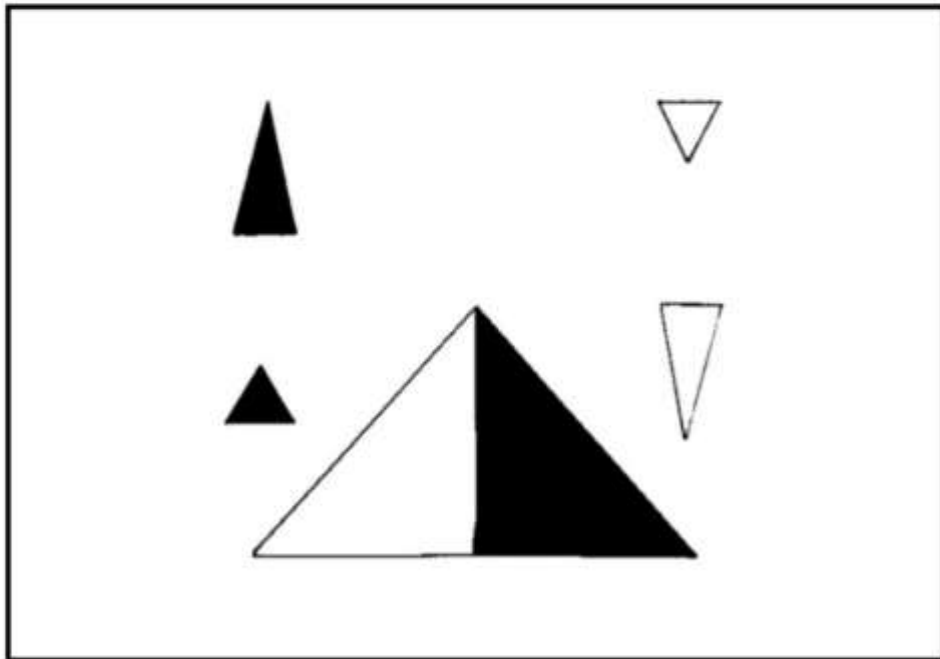

مثلت

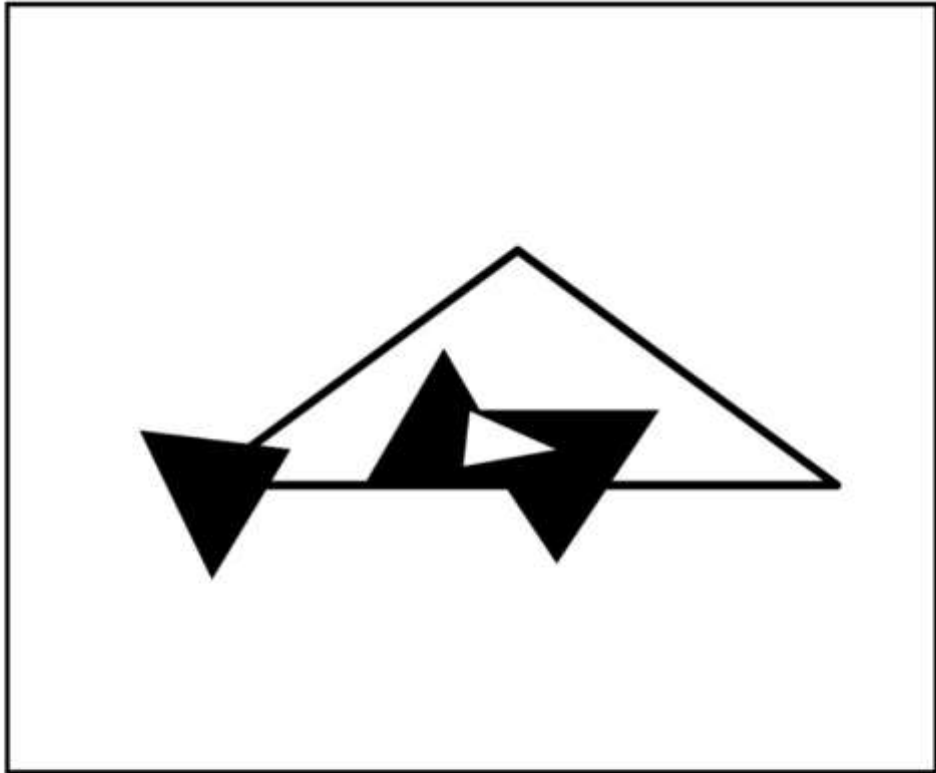

دایره

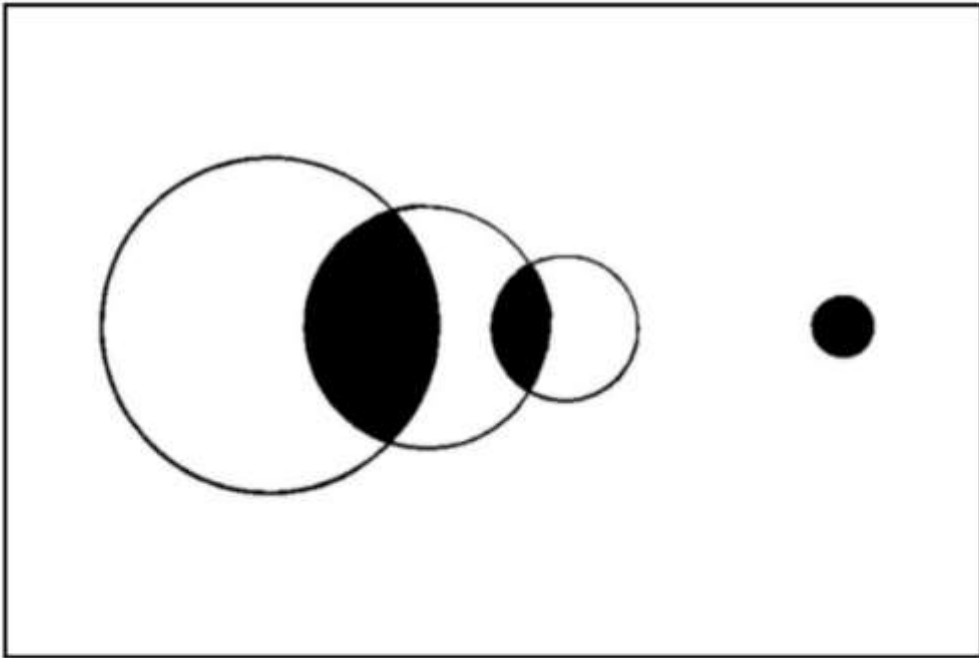

مثلث و دایره

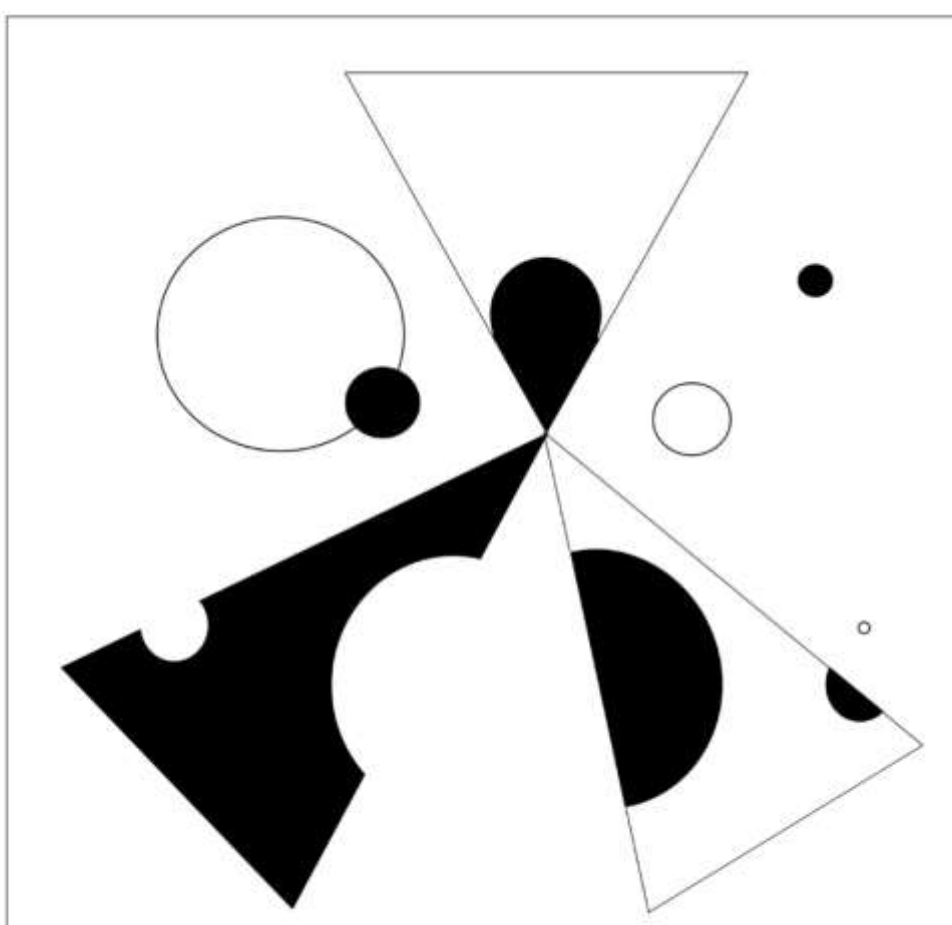

دایره و مربع

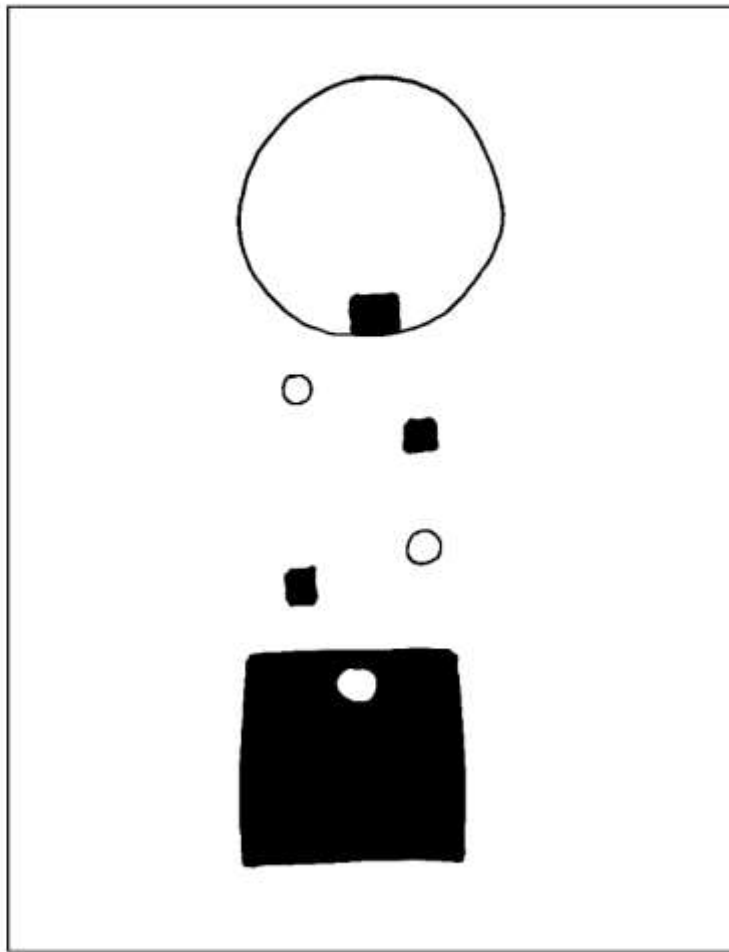

دایره و مثلث و خط

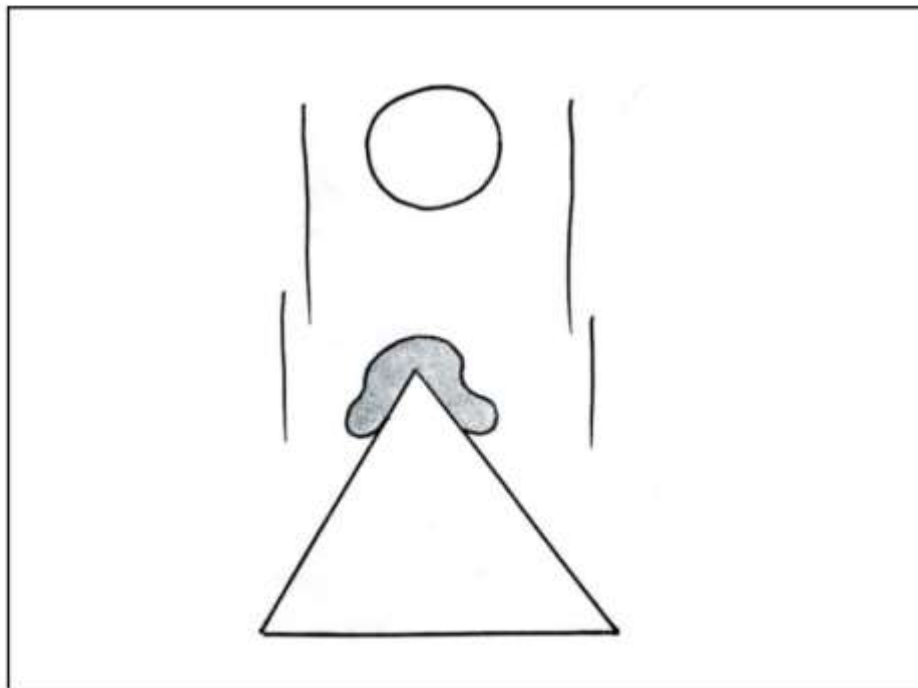

مربع و مثلث

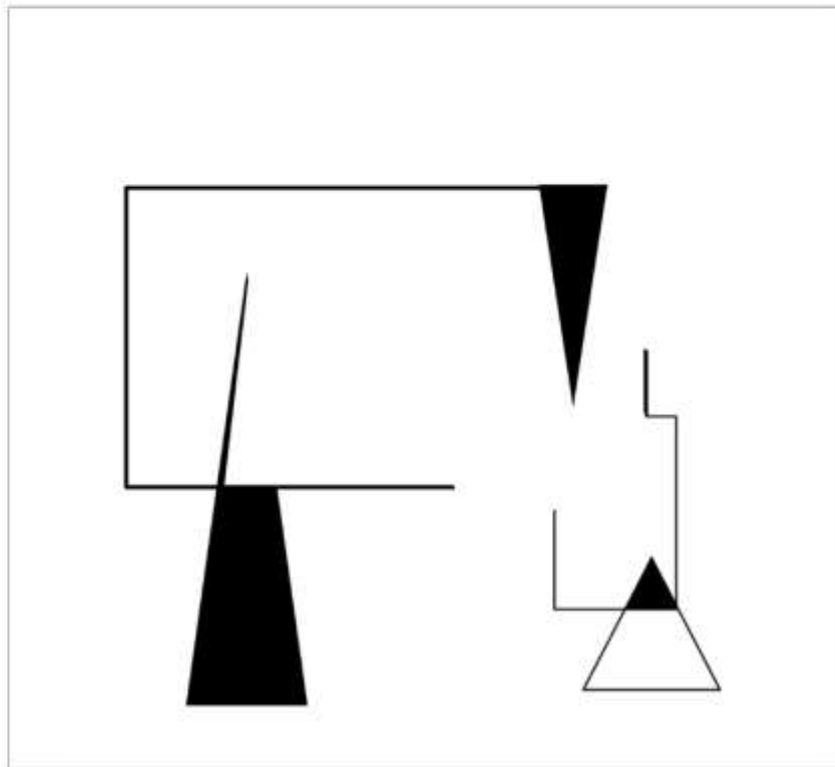

مربع و دایره و خط

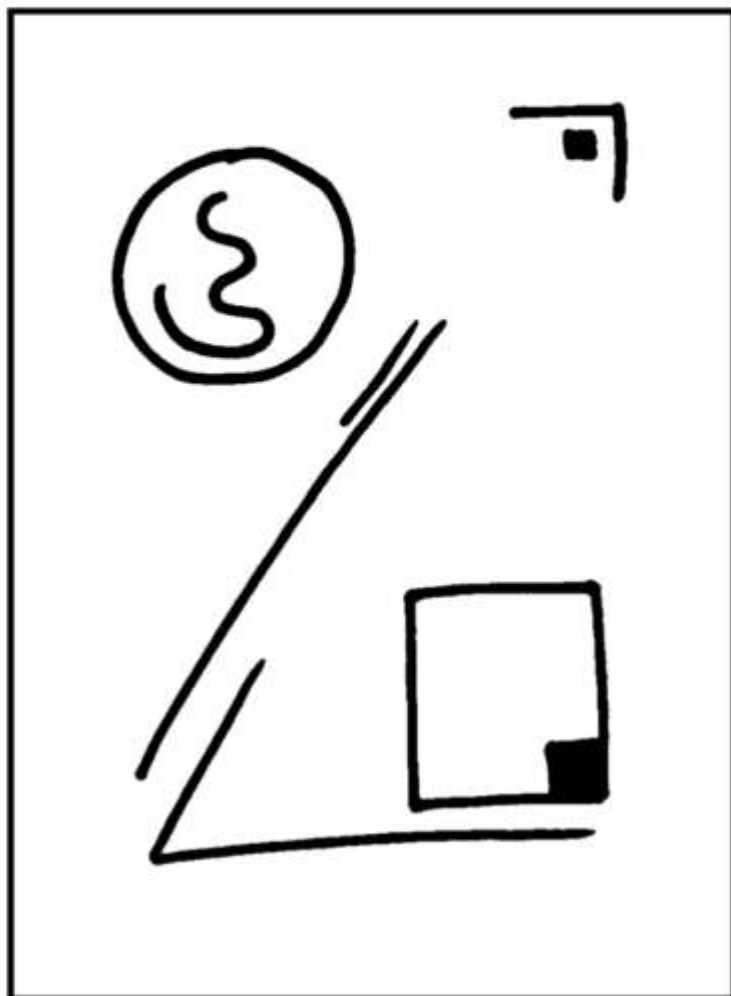

مربع مثلث خط

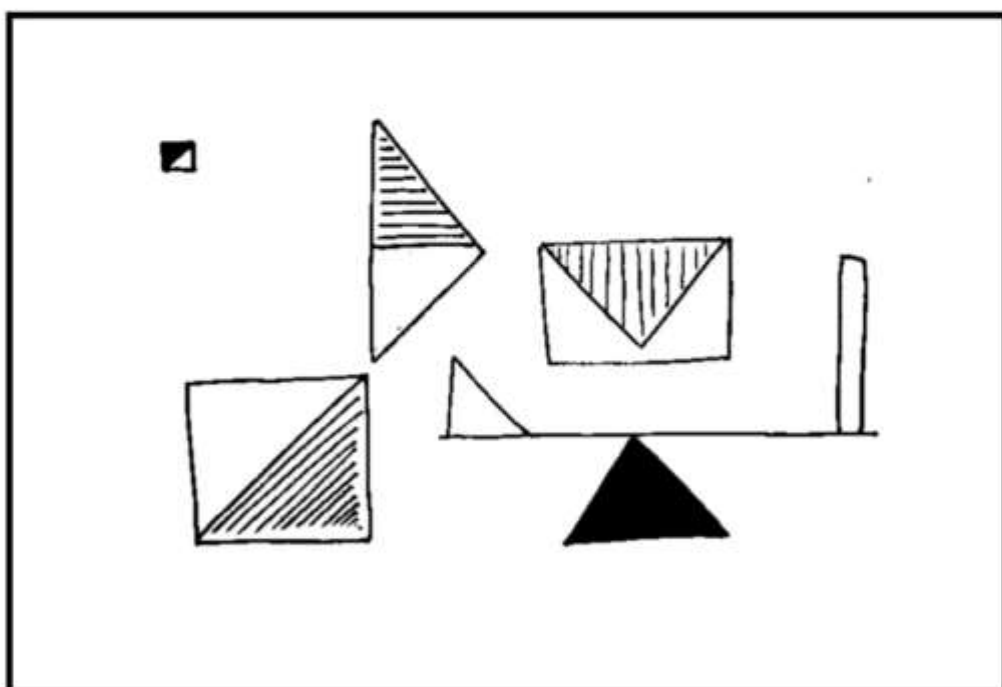

دایره مربع مثلث خط و خاکستری ها

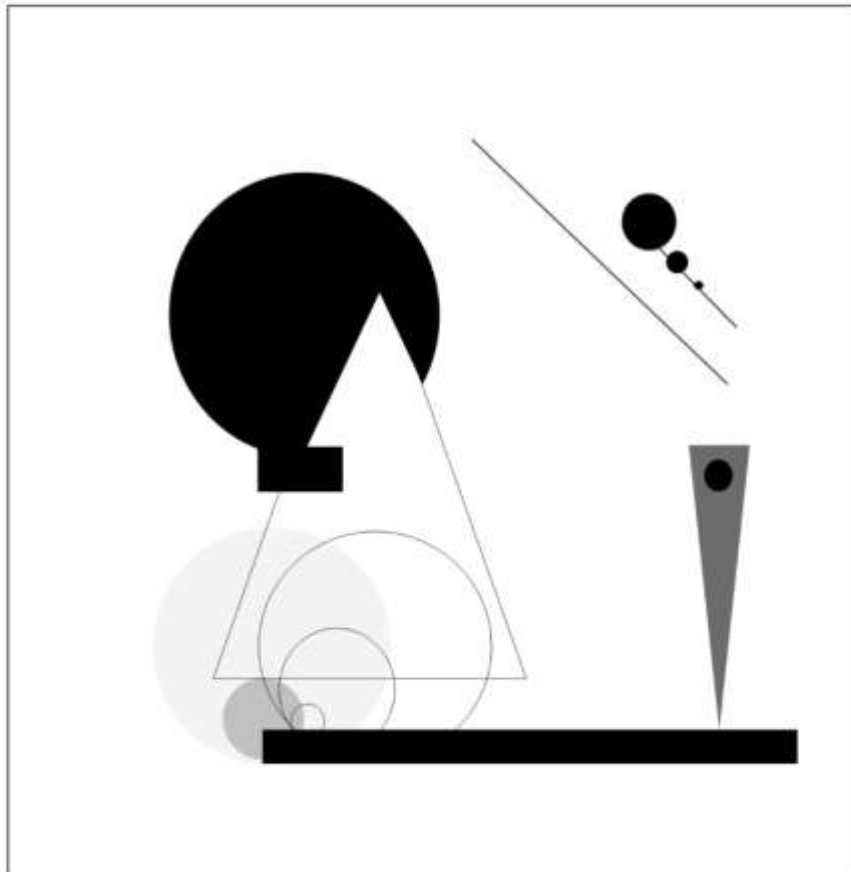

تأثیرِ کادرِ برِ تعادلِ ترکیبِ

بنّادی



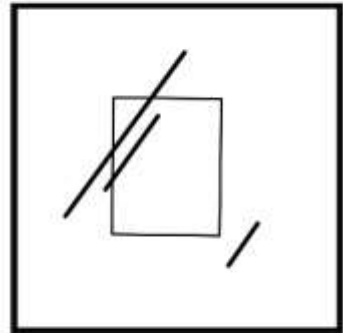
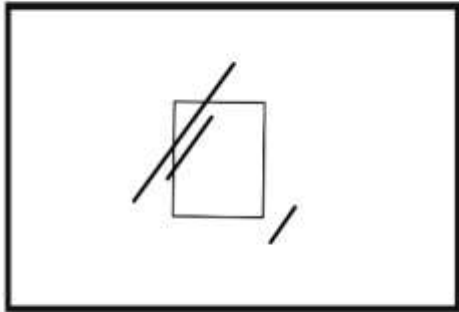
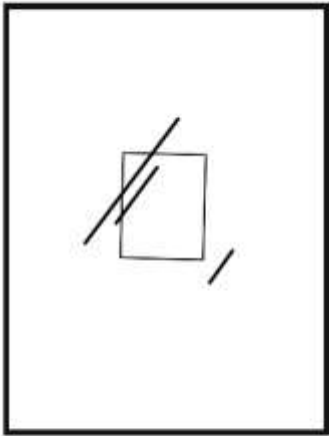

م. ق. م



فرم طبیعی



فرم طبیعی مجرد

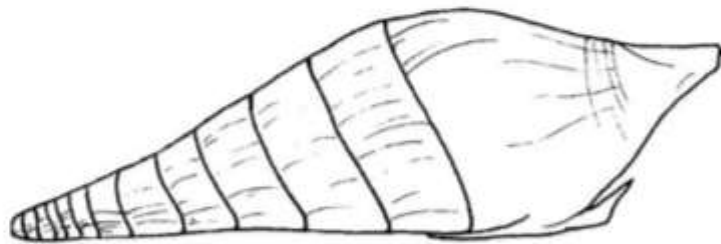

فرم طبیعی مجرد



فرم طبیعی مجرد

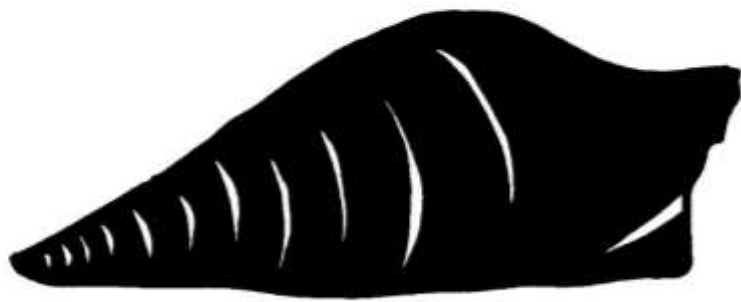

فرم طبیعی جمع

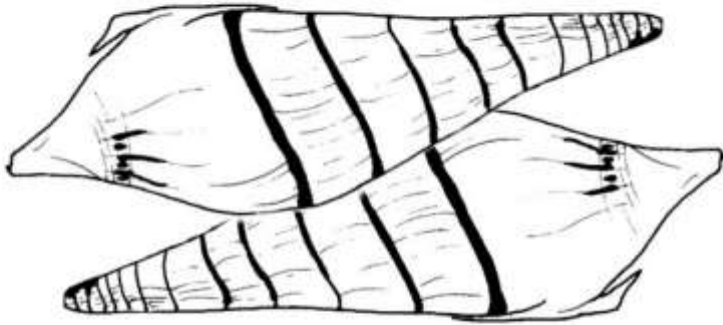

فرم طبیعی مرکب

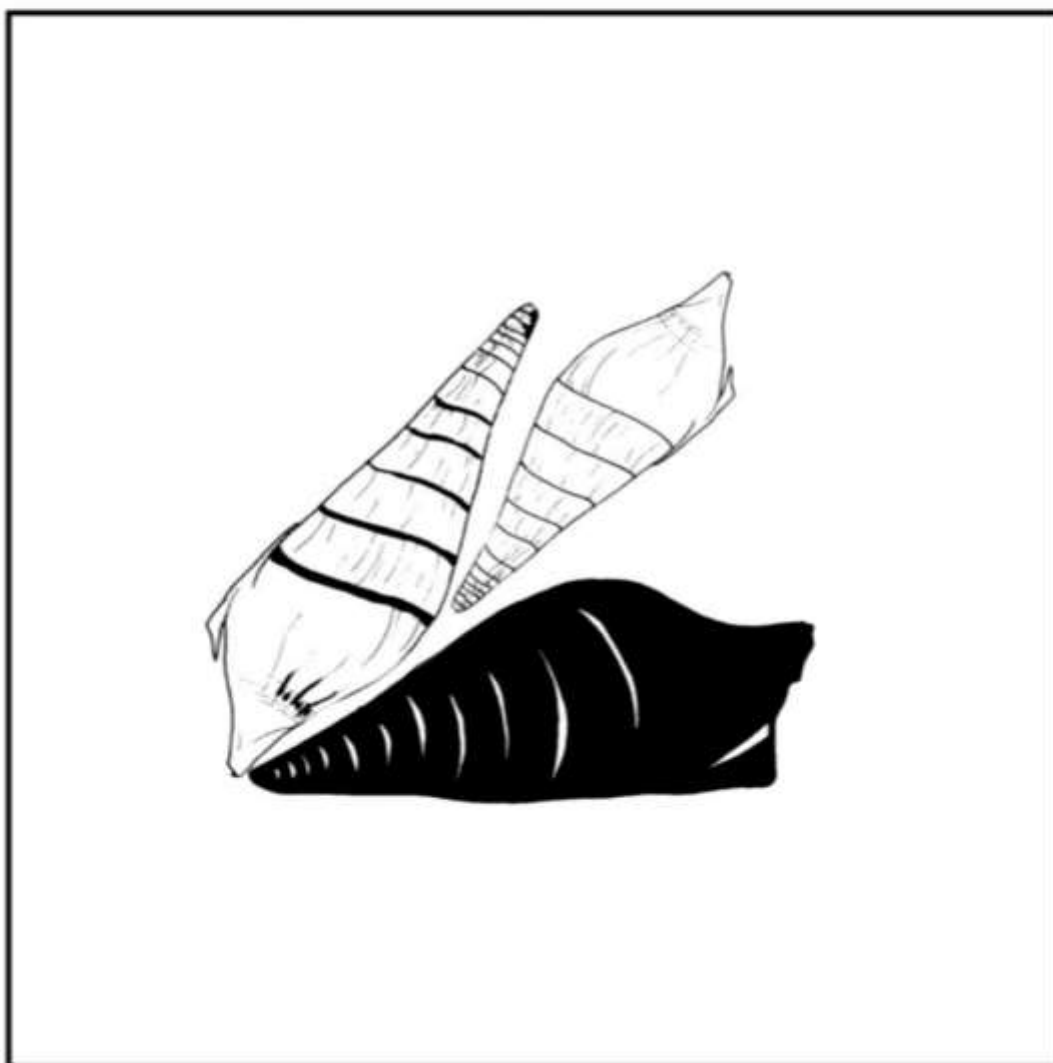

فرم طبیعی واحد

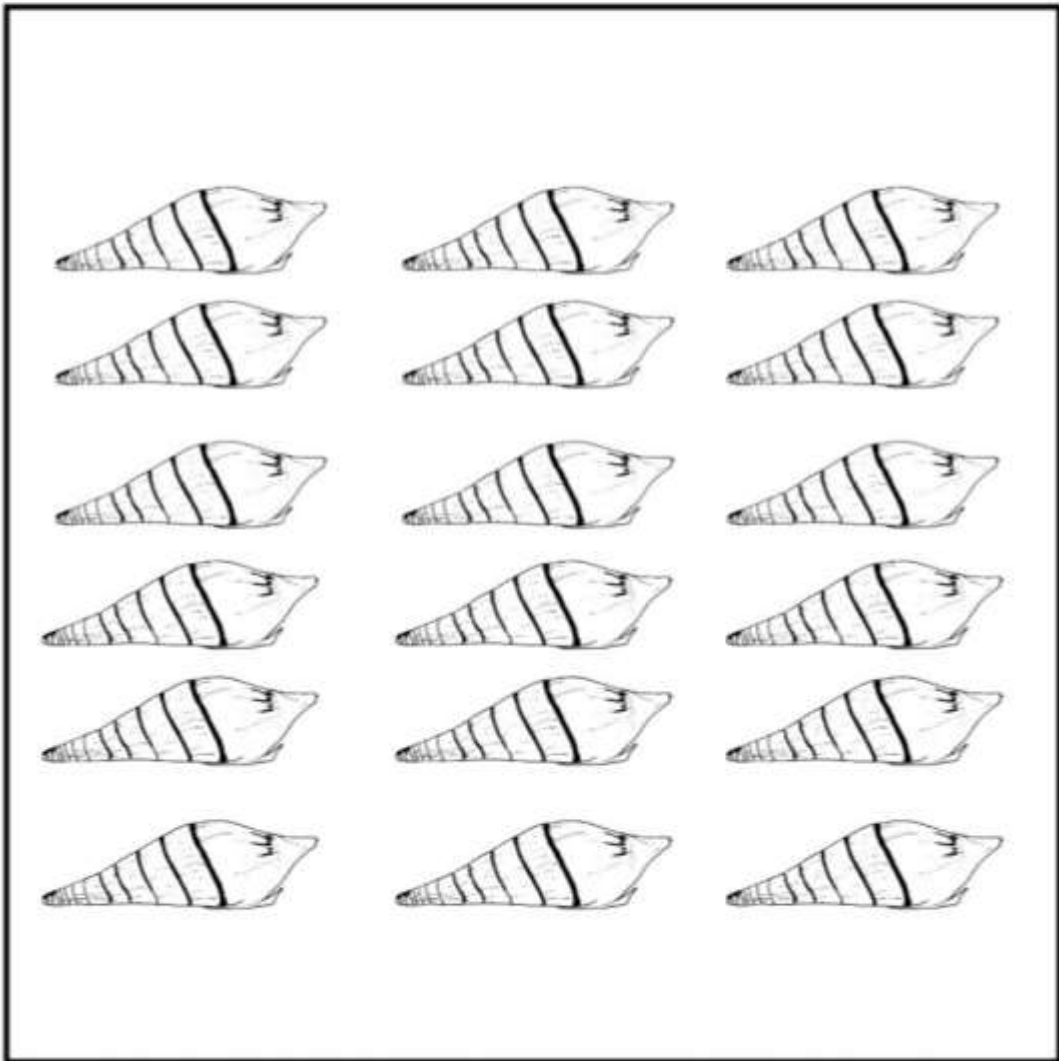

فرم طبیعی ابر واحد

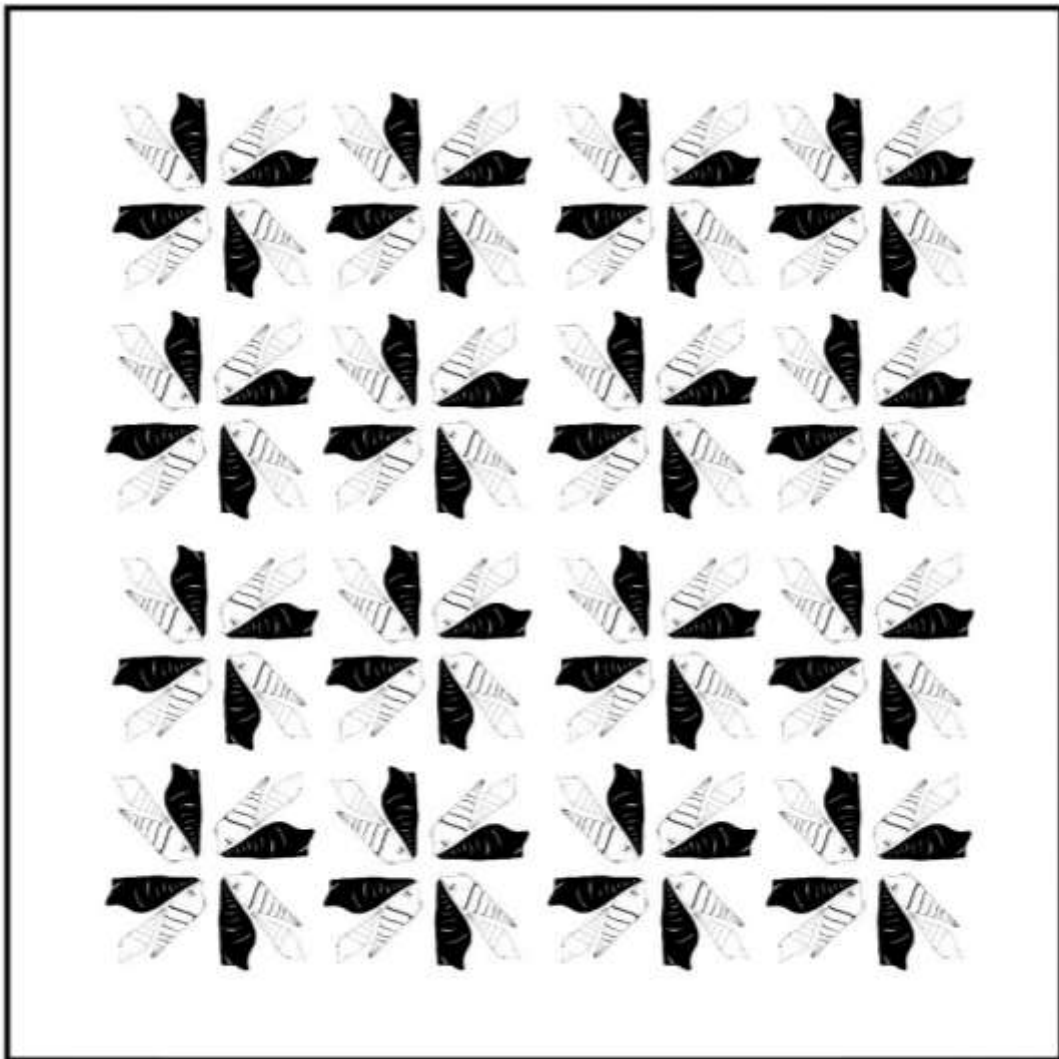

فرم مصنوعی



فرم مصنوعی مجرد

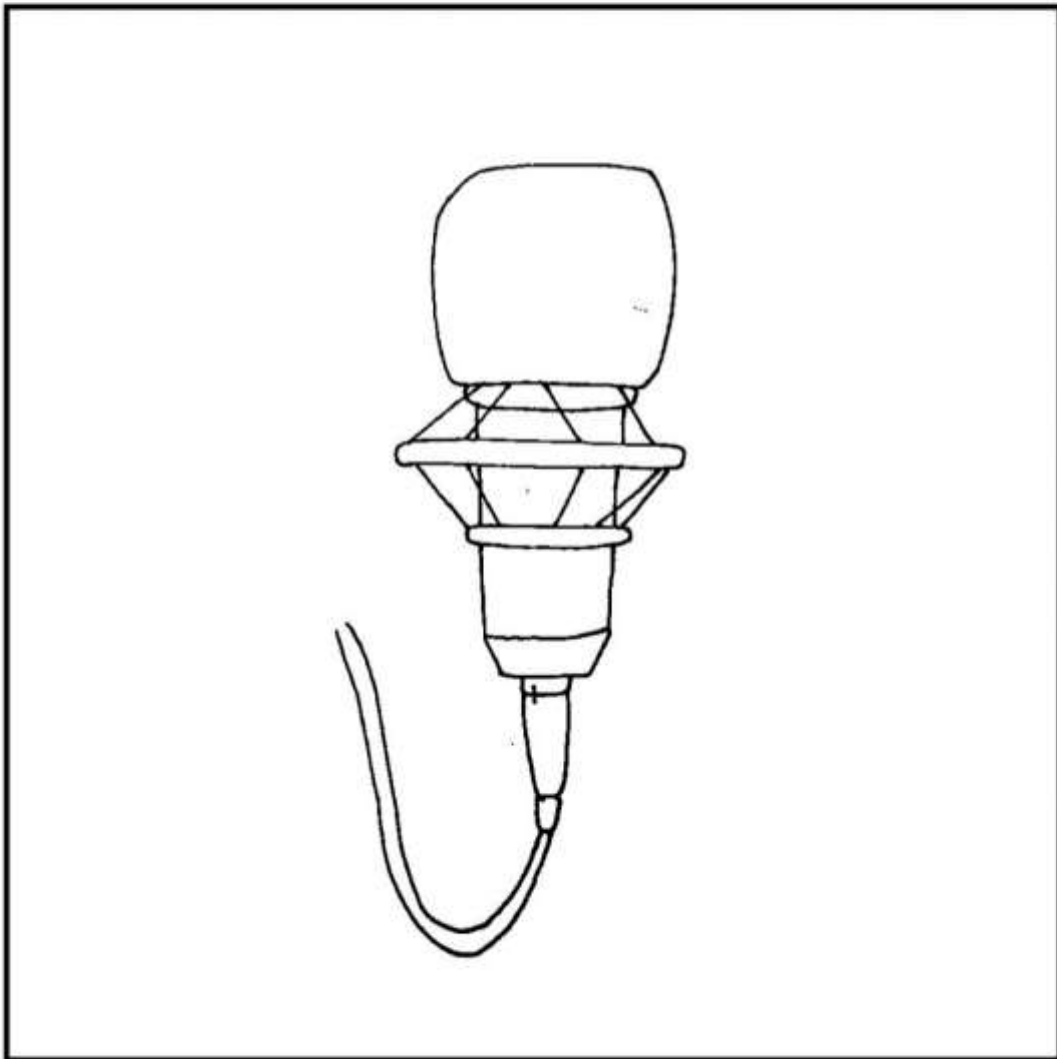

فرم مصنوعی مجرد



فرم مصنوعي جمع

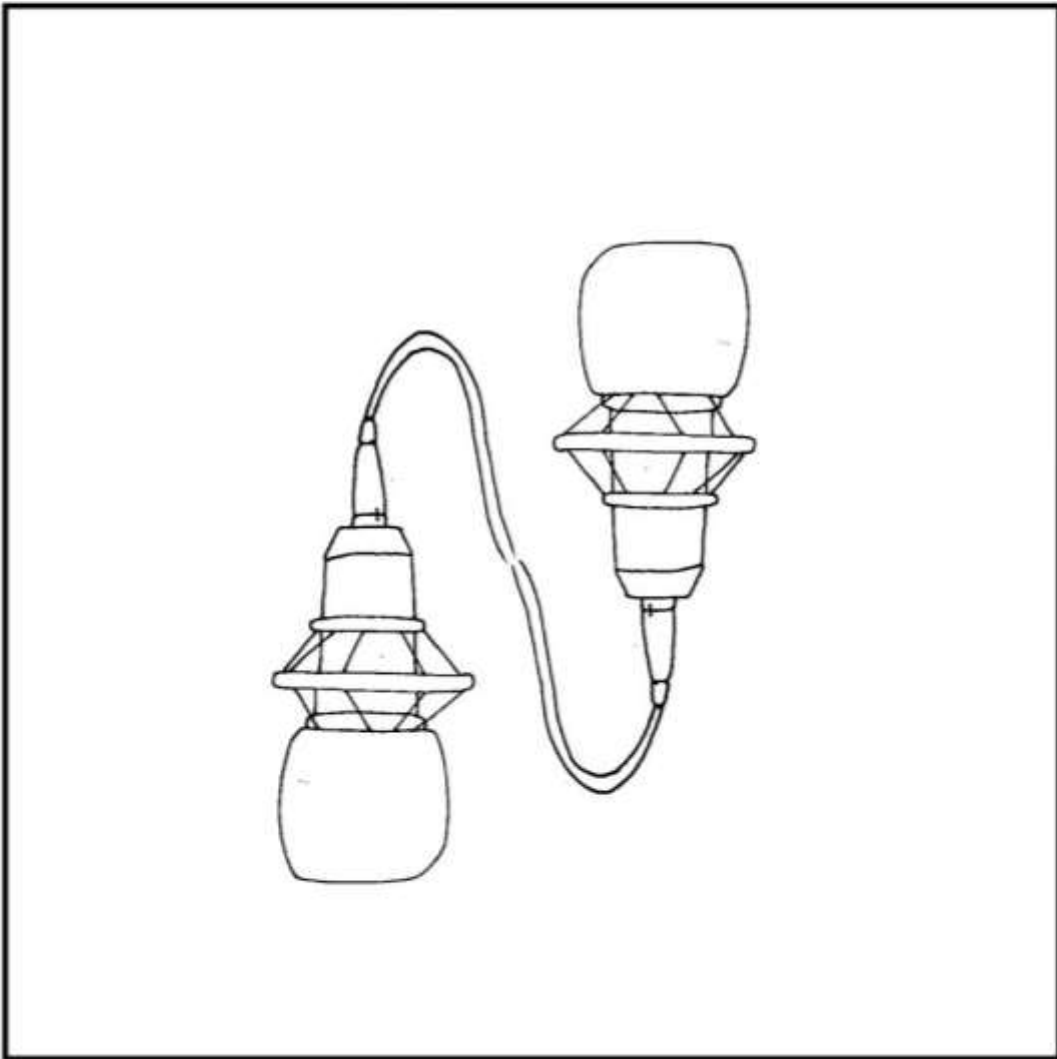

فرم مصنوعی مرکب



فرم مصنوعی واحد

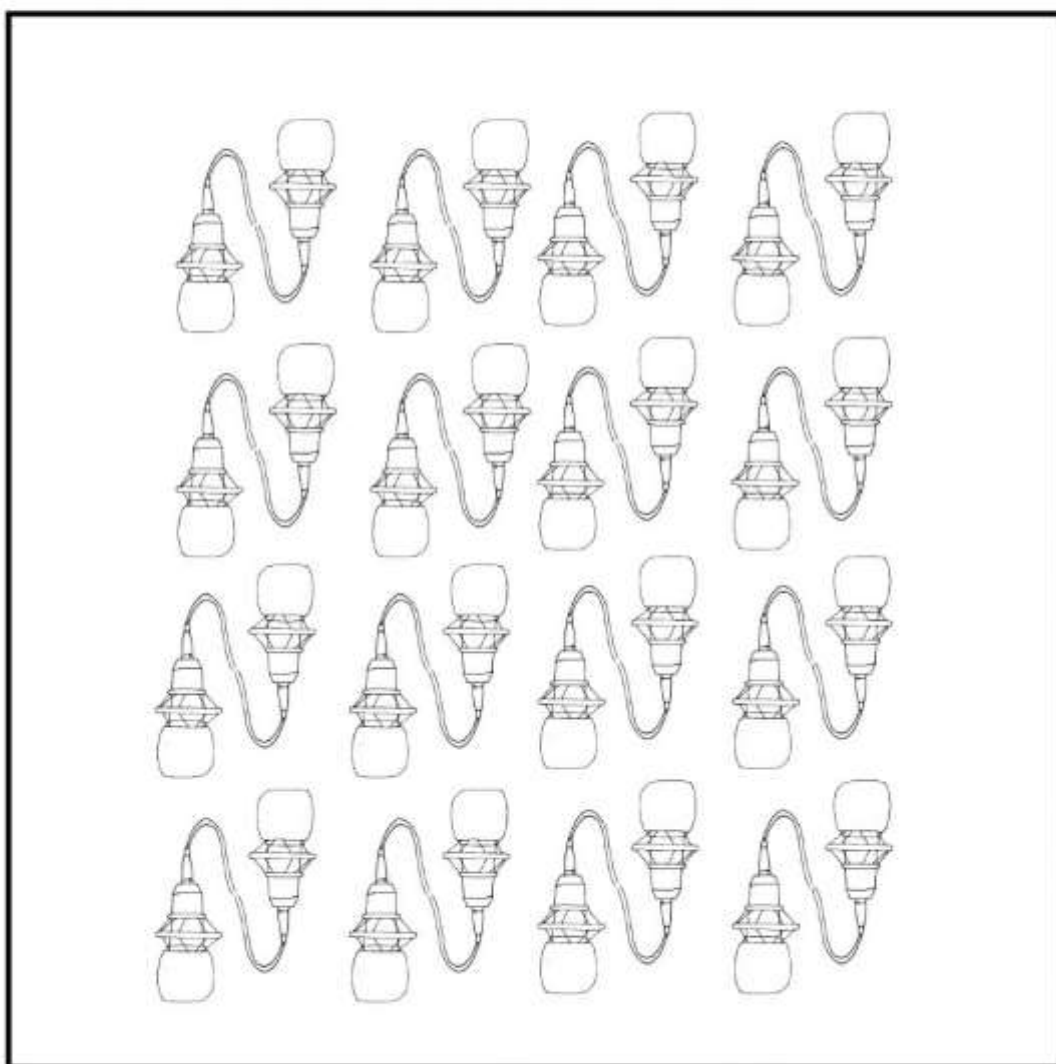

فرم مصنوعی ابرو احد



فرم زبانی مجرد



فرم زبانی مجرد



فرم زبانی جمع



جمع

فرم زبانی مرکب



فرم زبانی واحد

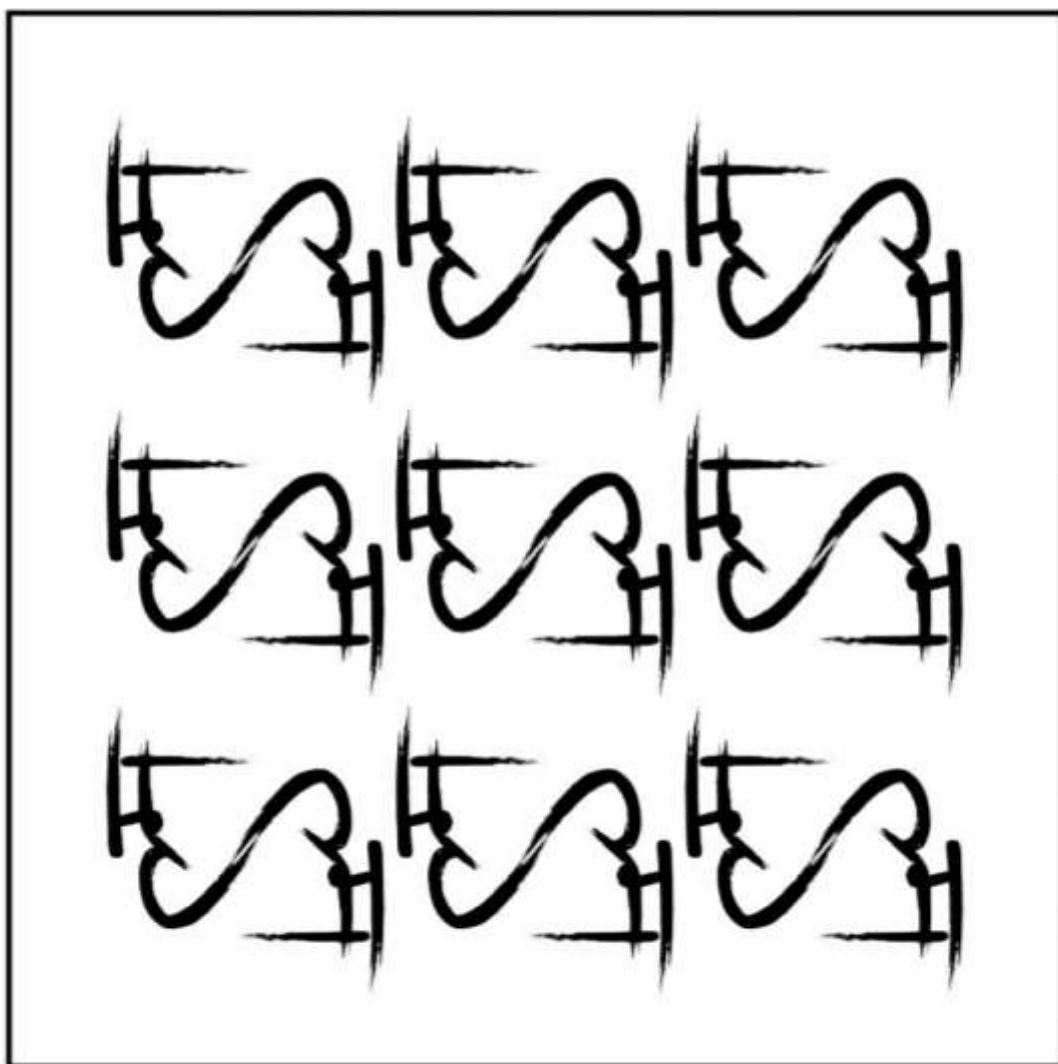

فرم زبانی ابرو واحد

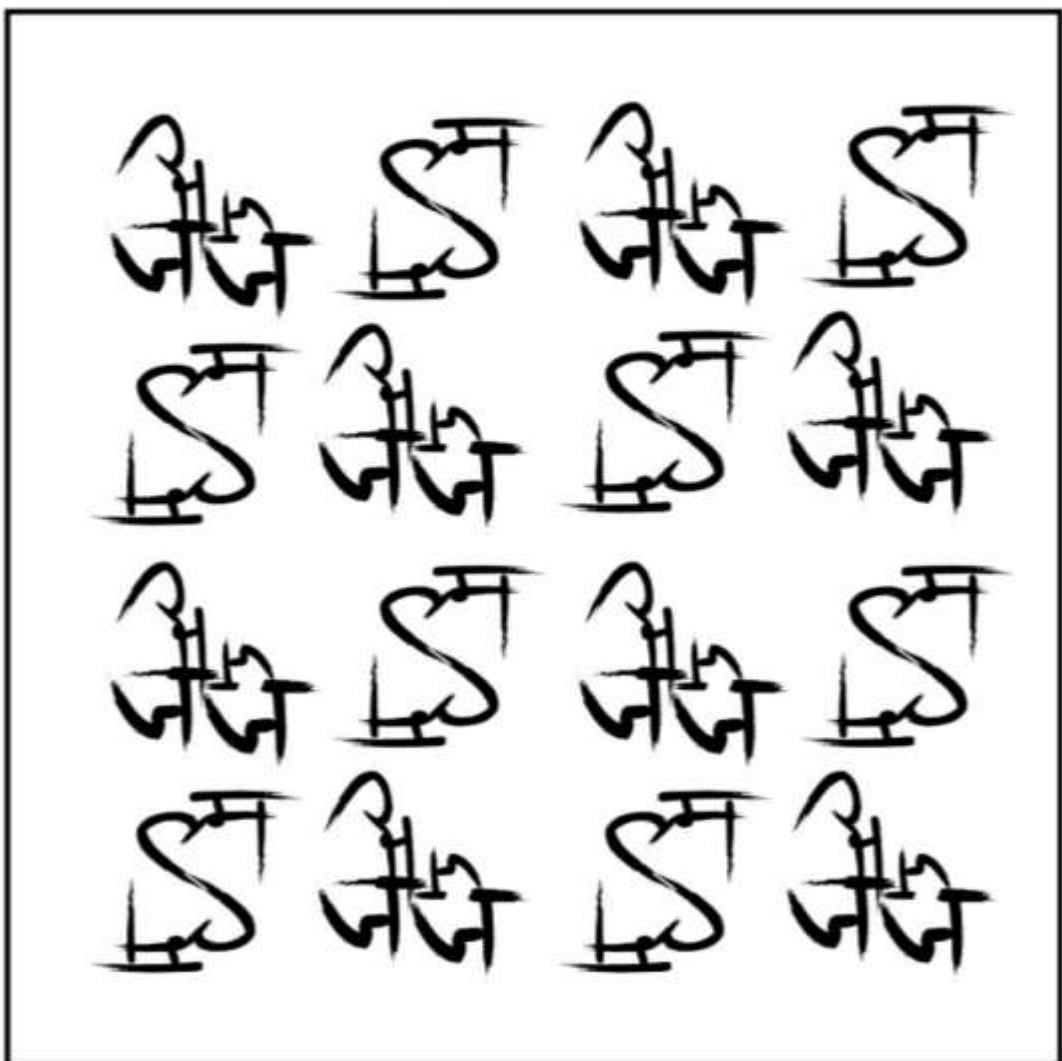

فرم انتزاعی مجرد

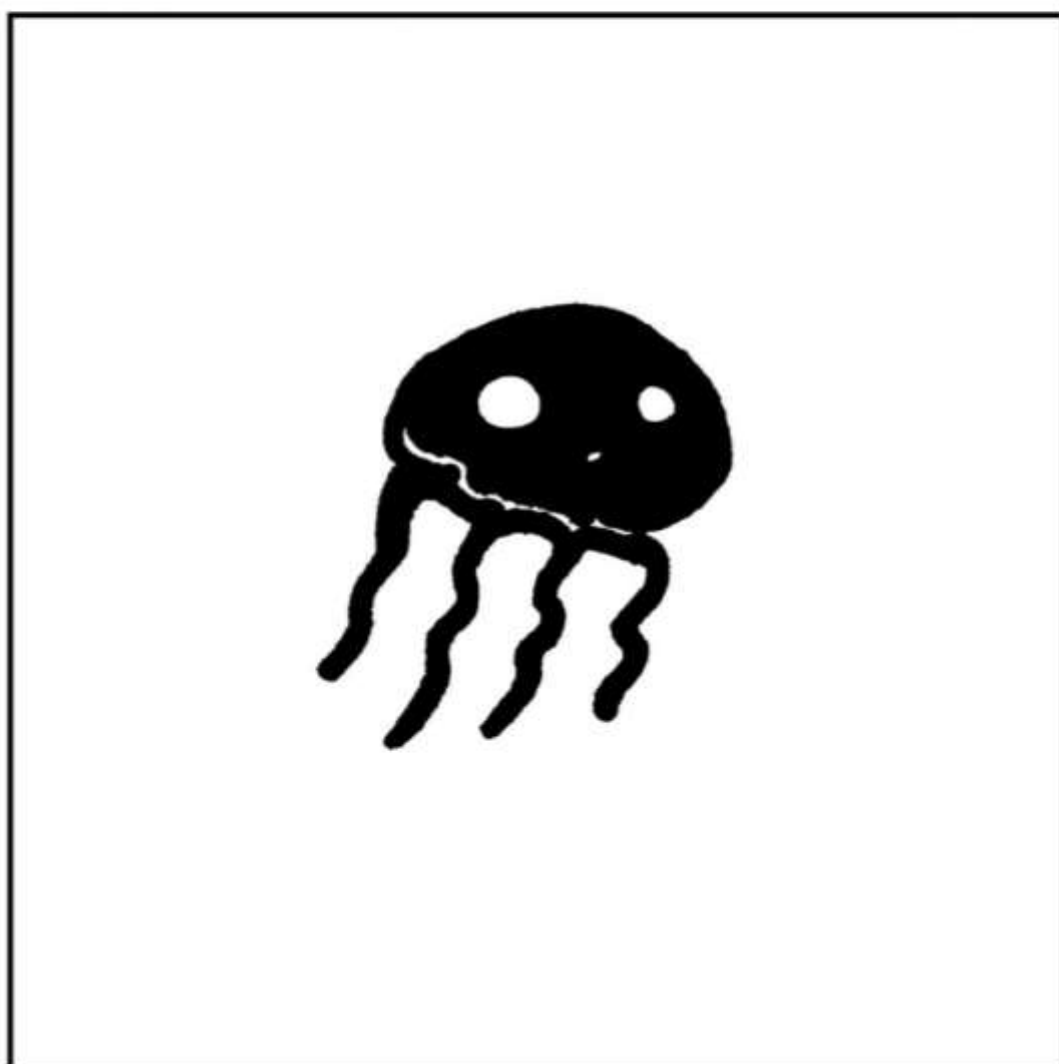

فرم انتزاعی جمع

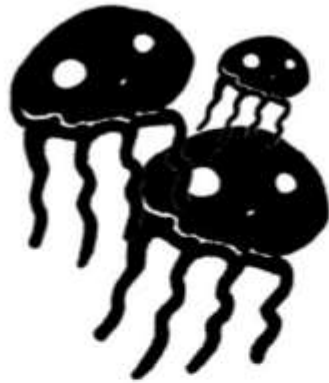

فرم انتزاعی مرکب



فرم انتزاعی مجرد



فرم انتزاعی واحد



فرم انتزاعی ابرو واحد

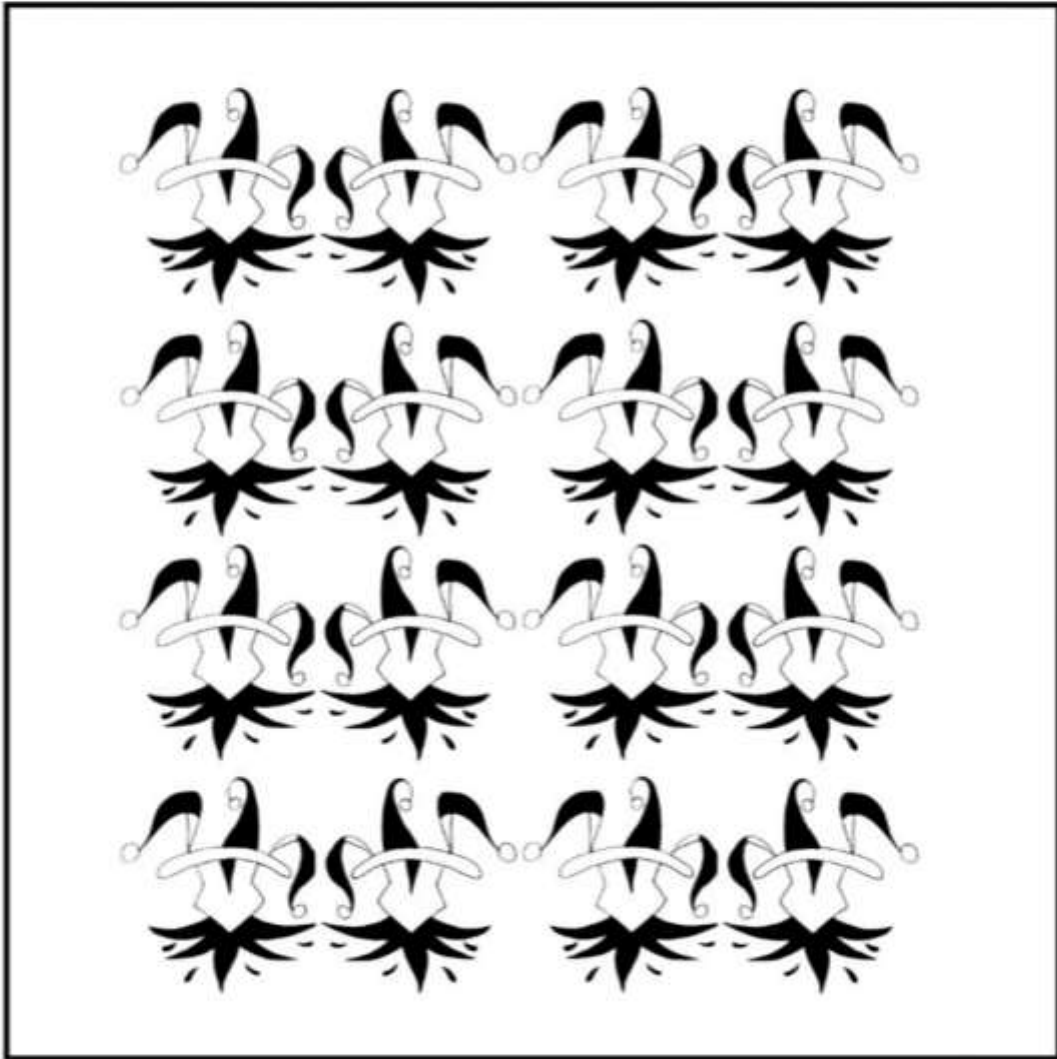



أبر واحد

روابط متقابل فرم ها

تفریق  در هم پوشانی 

مماس و
تفریق و
تقاطع  تفریق 



ادغام

تداخل

فرم واحد «فرم ادغام شده»

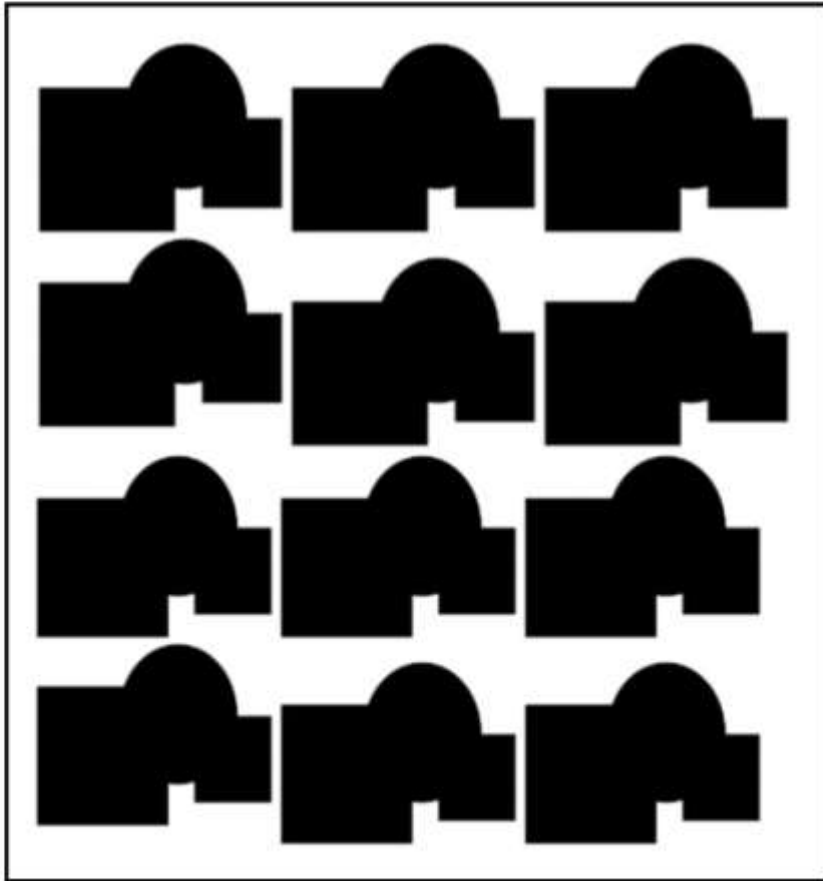

ابر واحد تمامی فرم های حاصل از روابط فرم ها

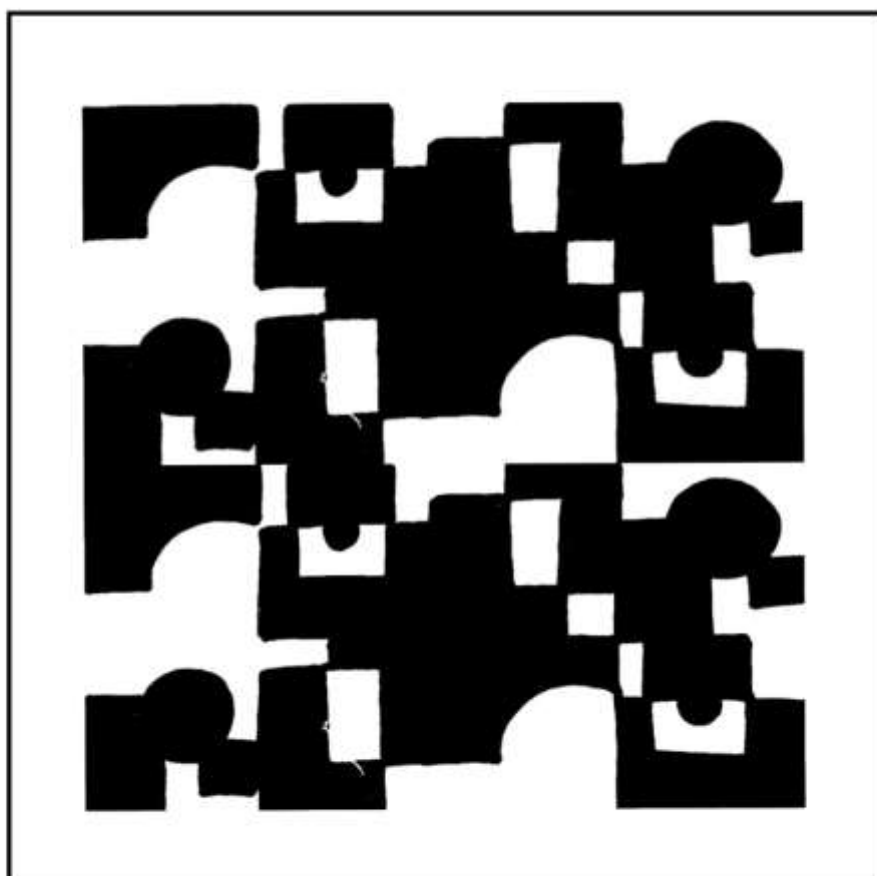

افزایش تکرار در ابر واحد پیشین

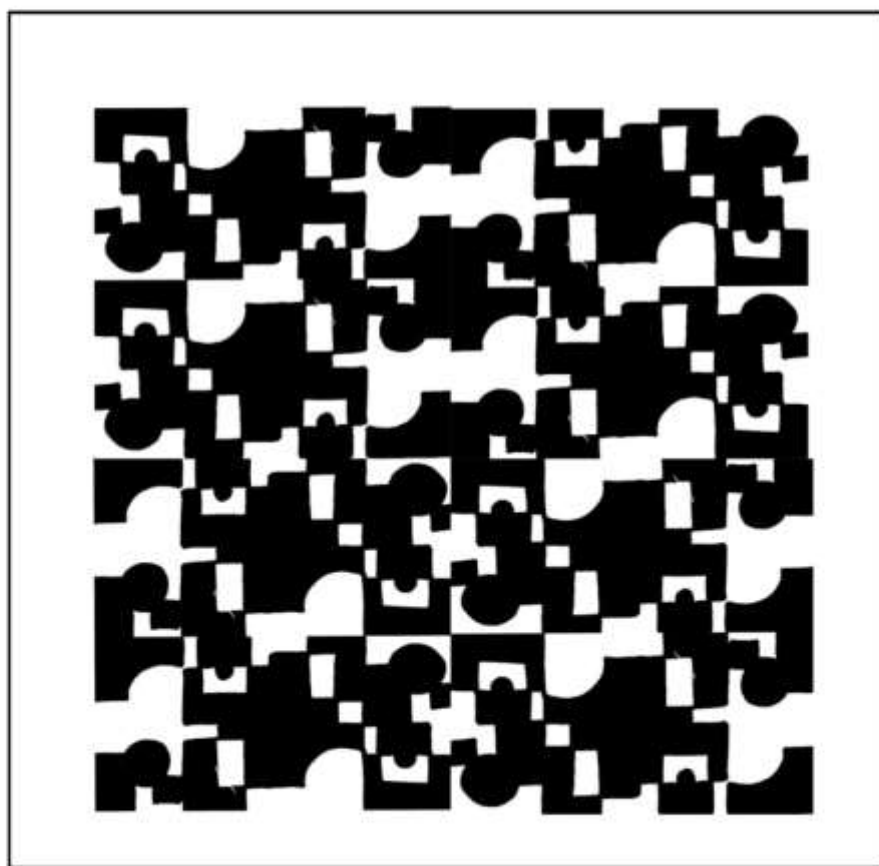

تلفیق دو ابر واحد

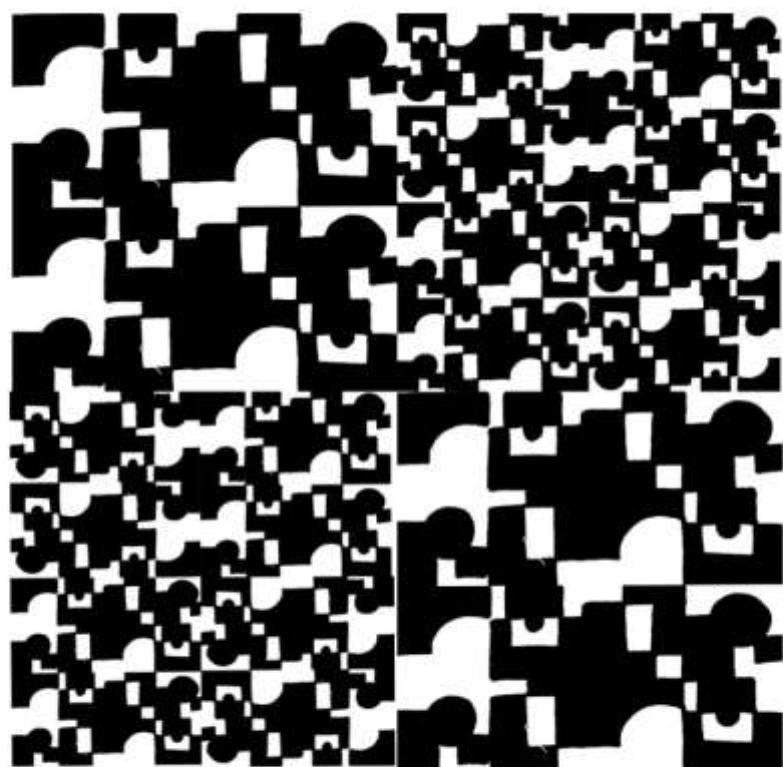

تلفیق سه ابر واحد

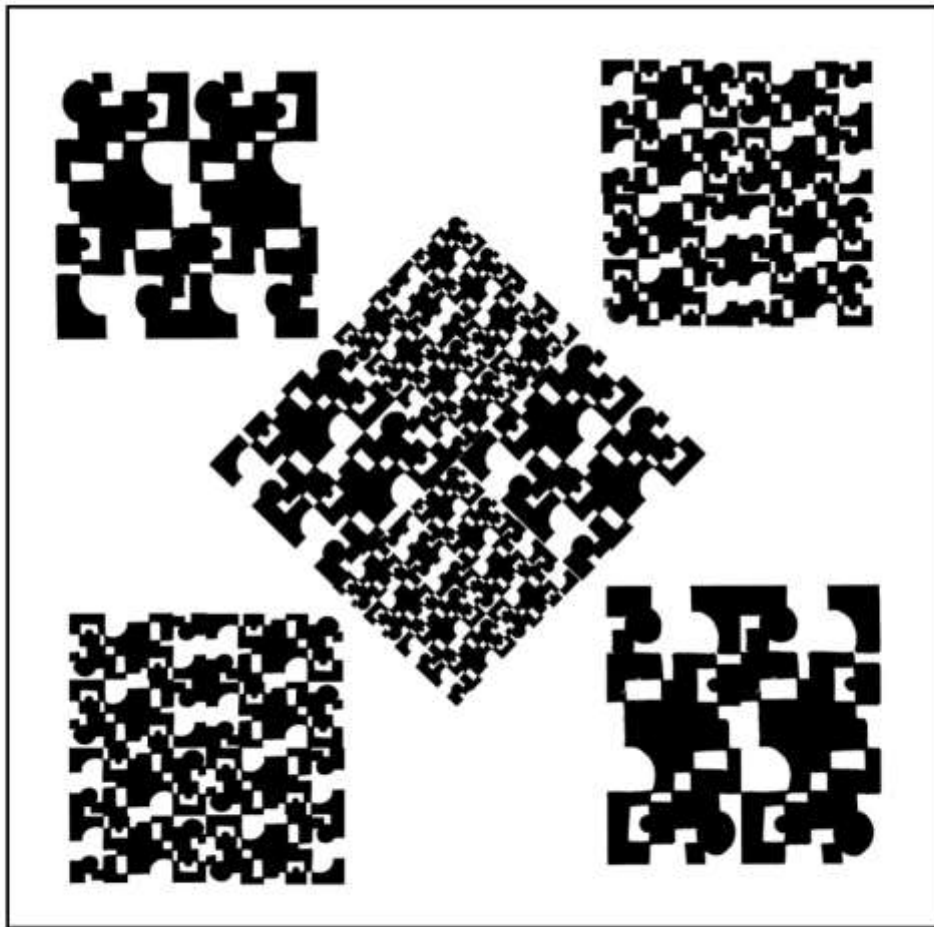

تکرار بیشتر ابر واحد پیشین

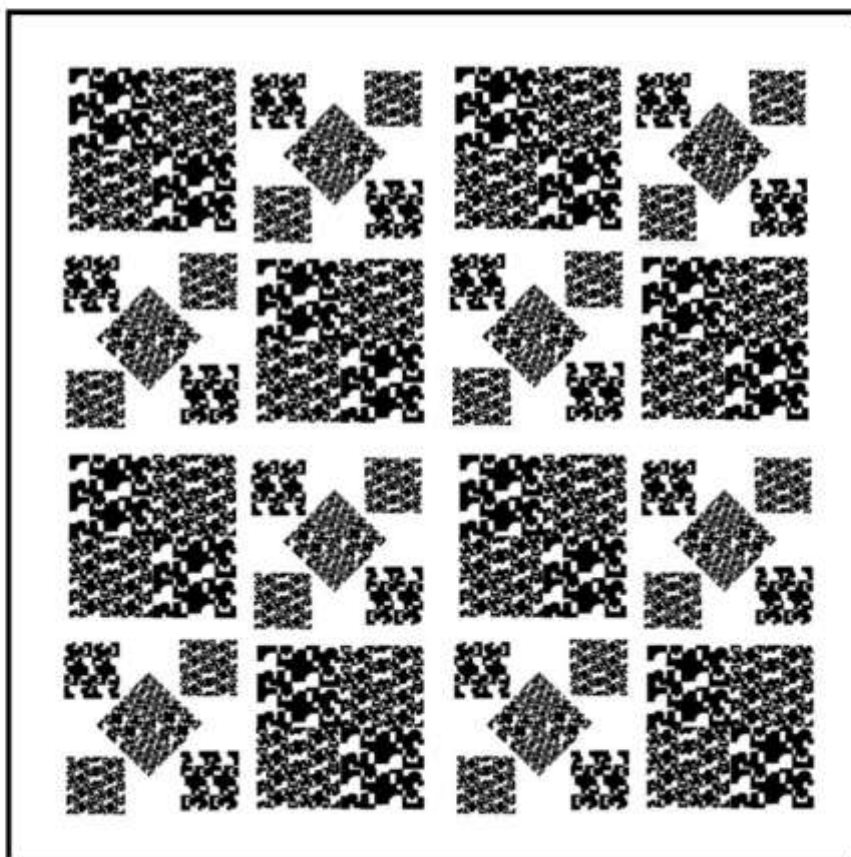

بِجَا
زِيَه

اَشْكَال



تجزیه دایره به مثلث

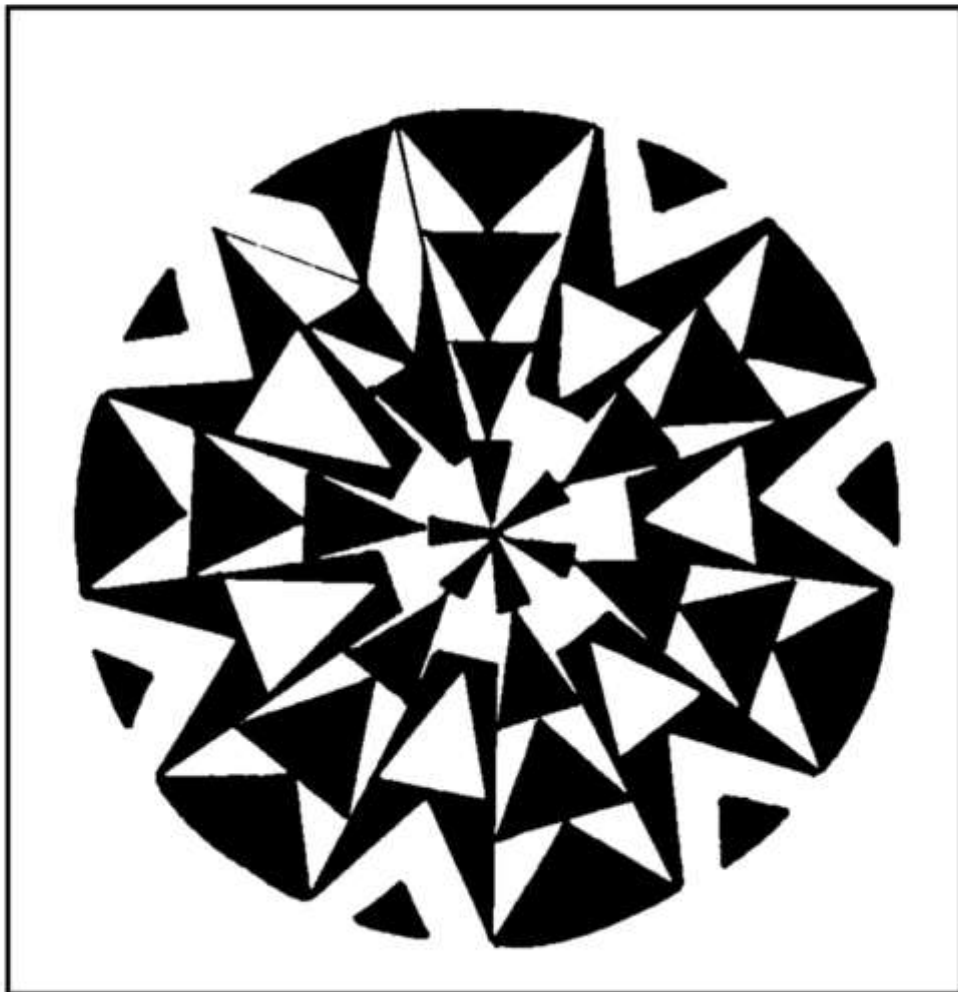

مربع به مثلث

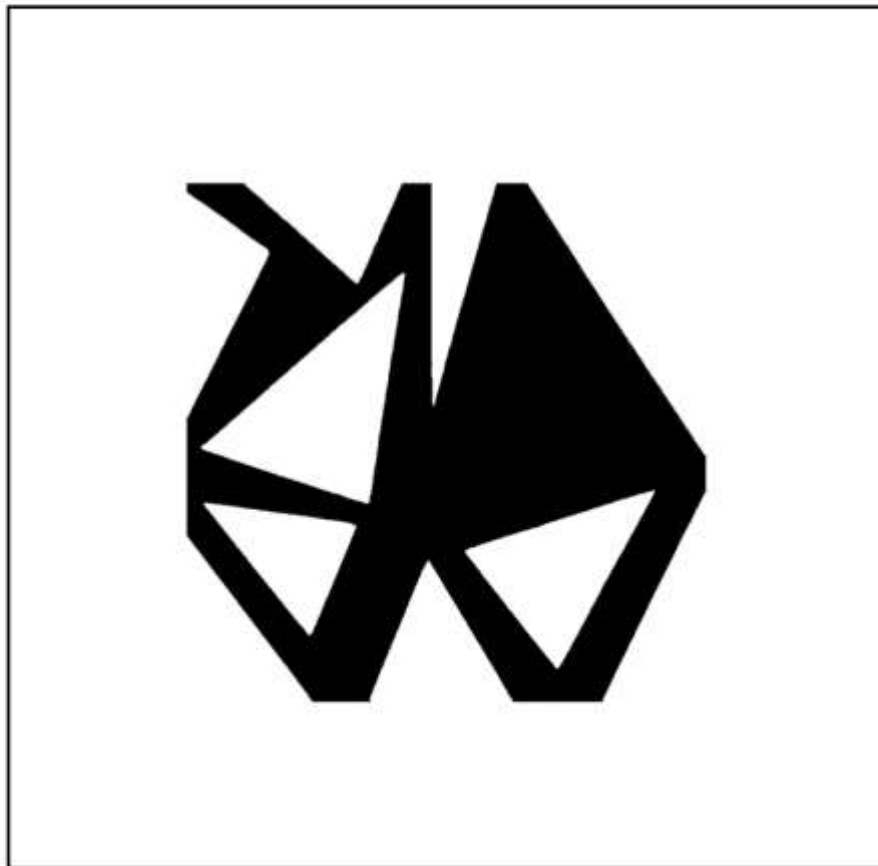

دایره به مثلث

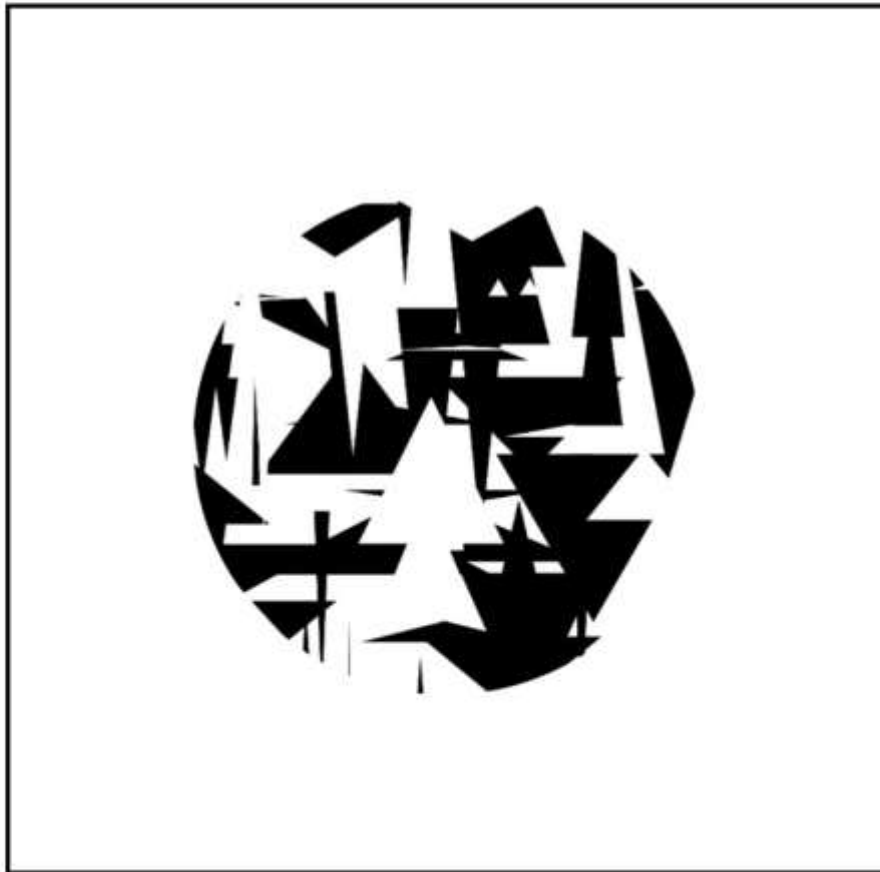

مربع به مثلث

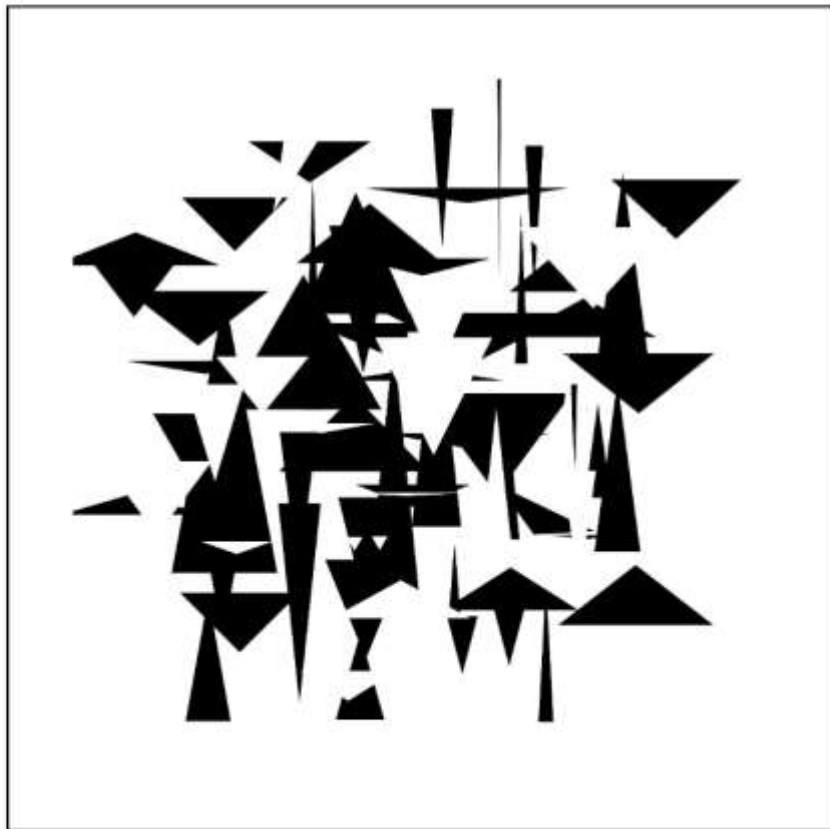



ترکیب بندی با

تکرار

استمرار دو جانبه

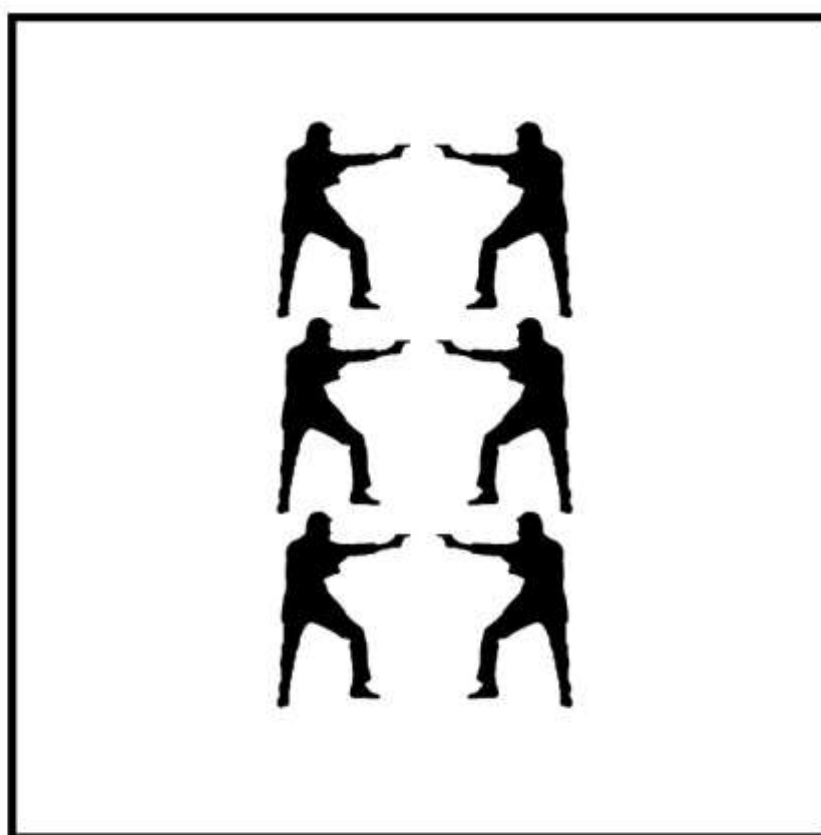

استمرار چهار جانبه

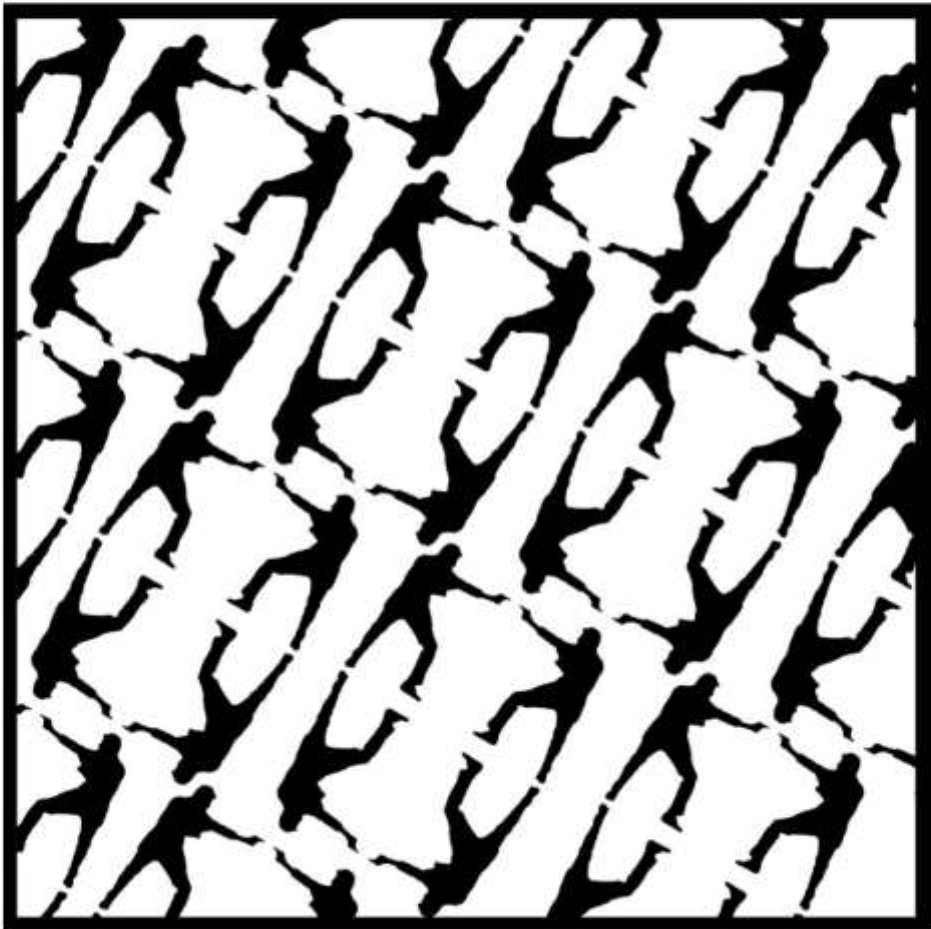

استمرار چهار جانبه

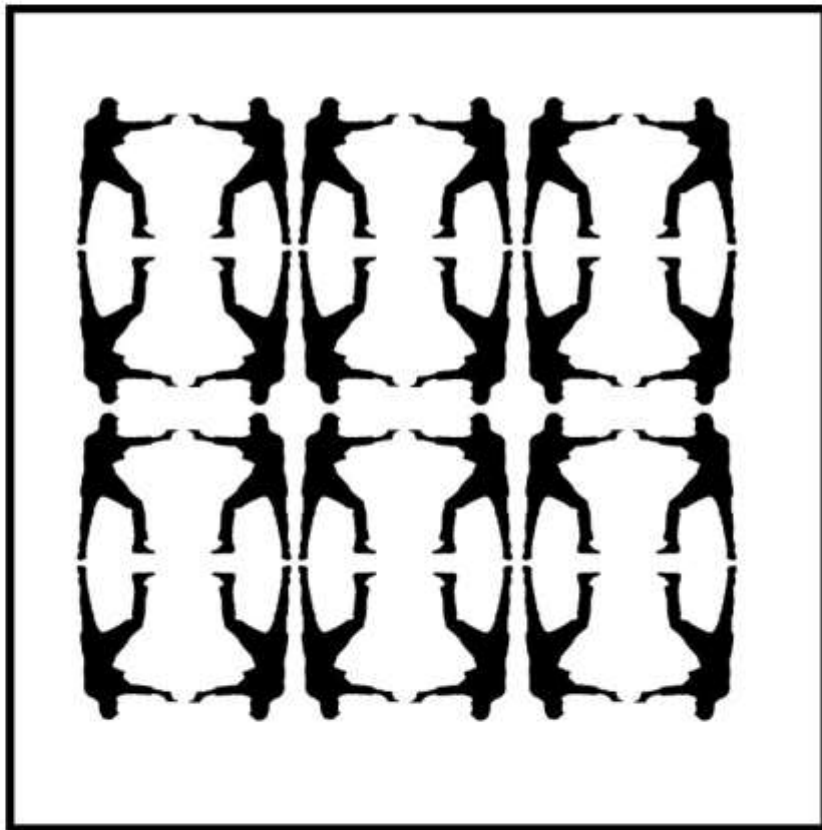

استمرار شش جانبه



گسترش و تنوع ساختار تکرار

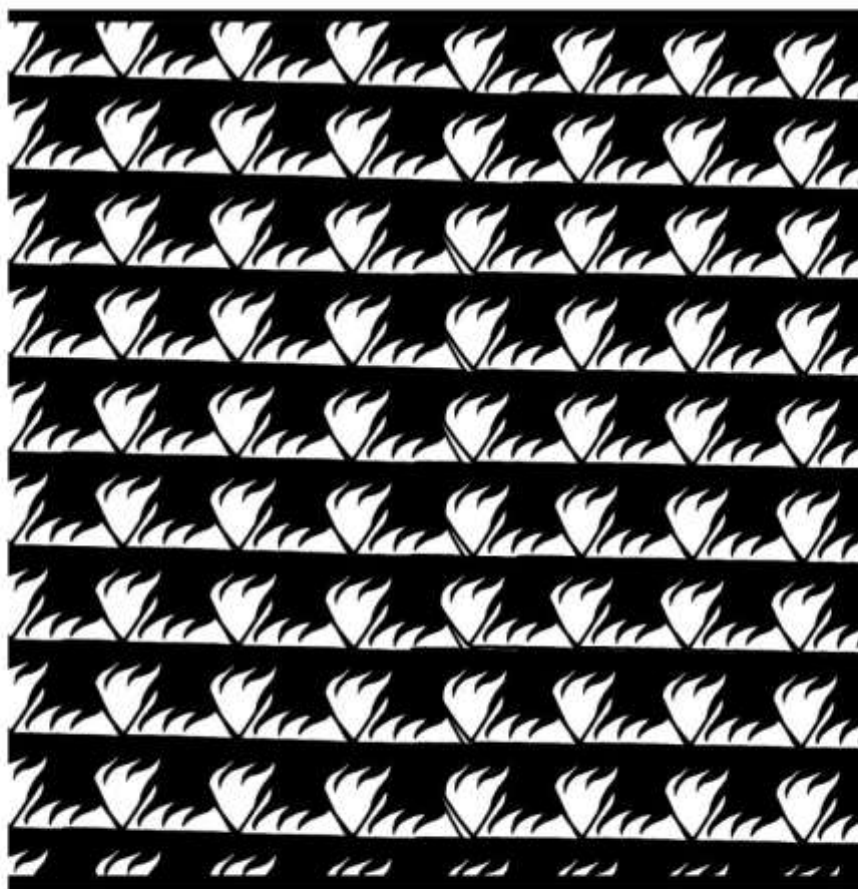

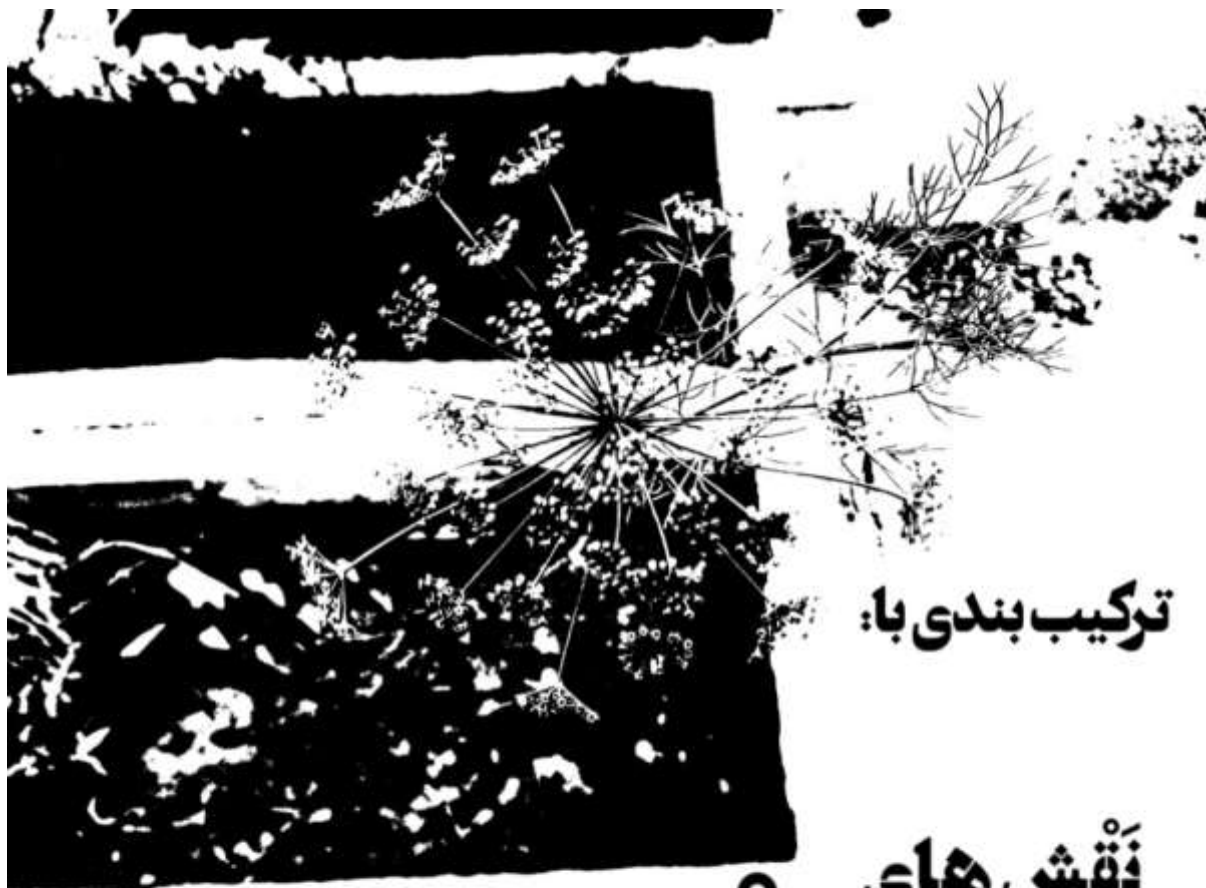

ترکیب بندی با:

نقش های

شعاعی

نقش شعاعی کامل. نمونه طبیعی

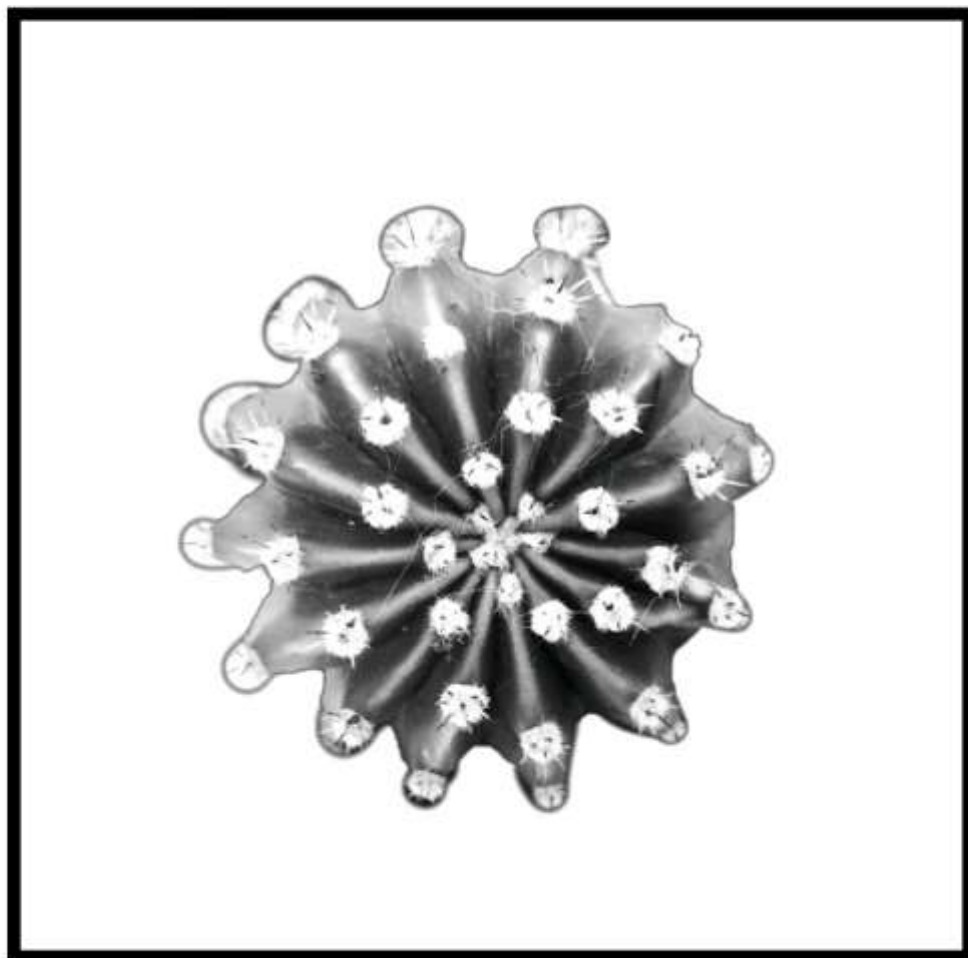

نقش شعاعی کامل

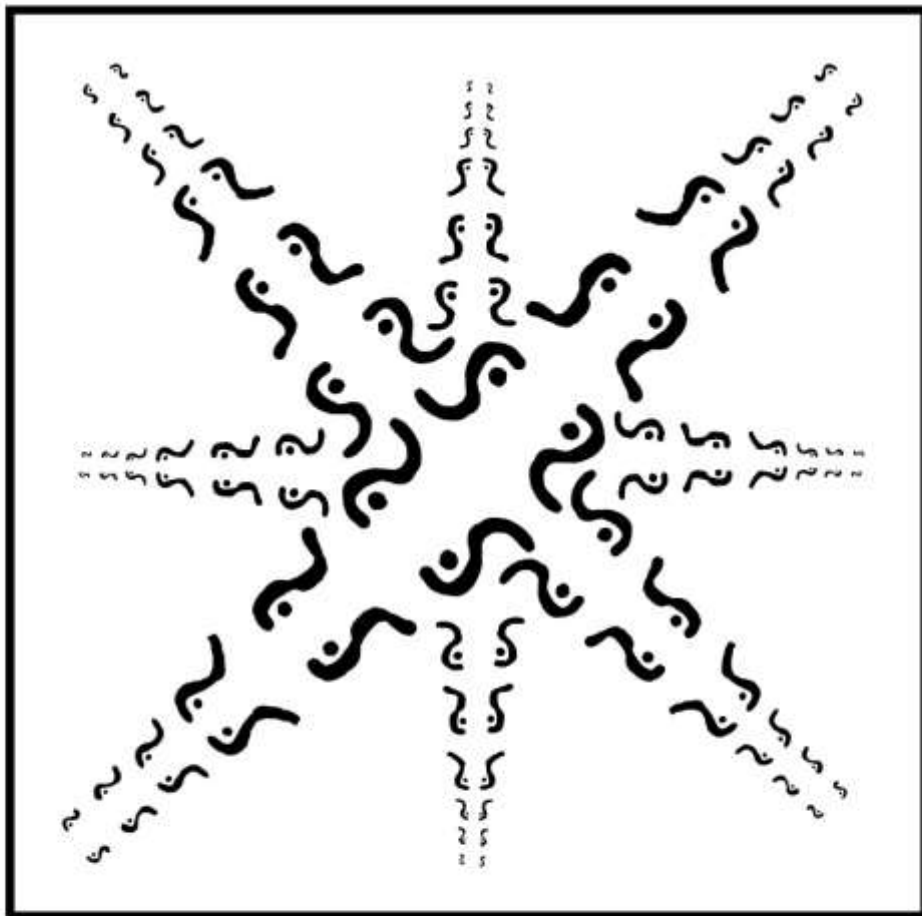

نقش شعاعی کامل

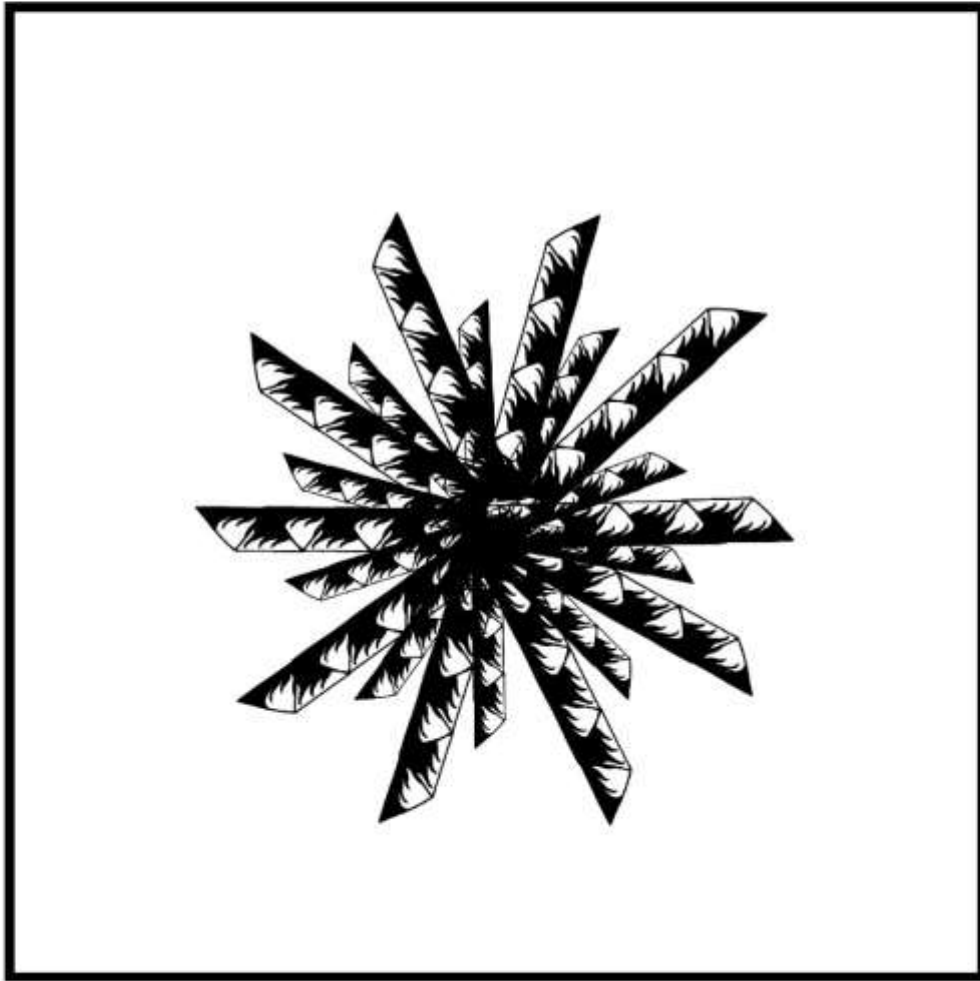

نقش شعاعی کامل

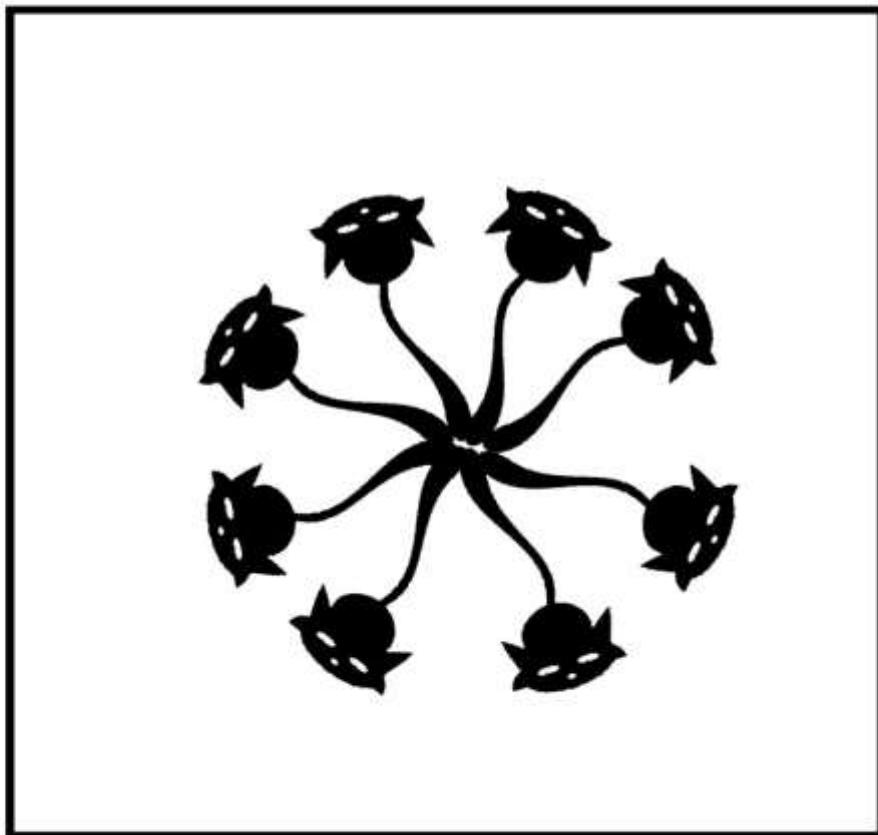

نقش شعاعی مقطع



چرخش و انتقال

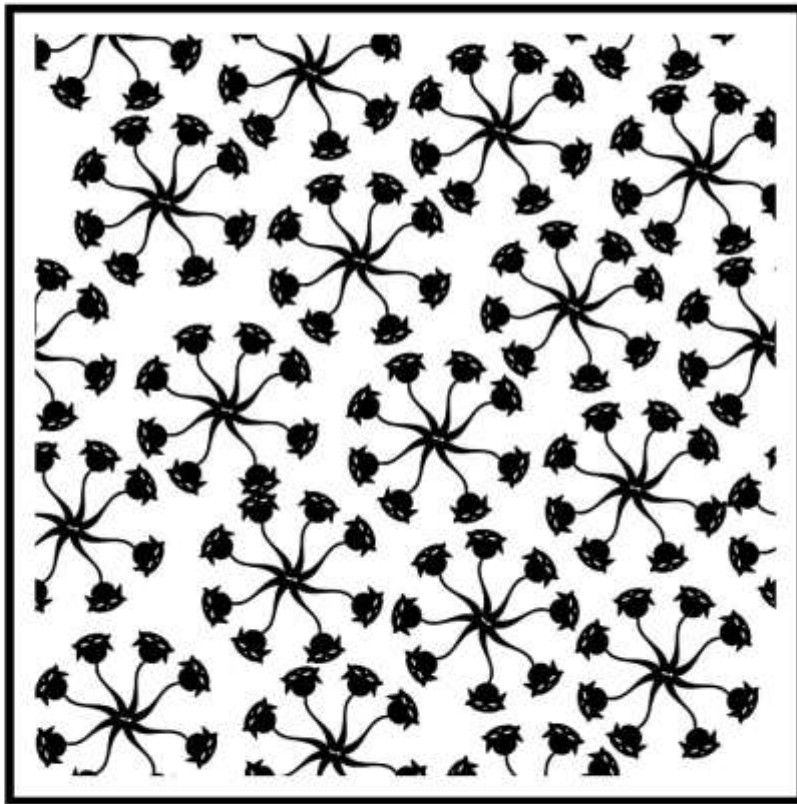

چرخش و انعکاس

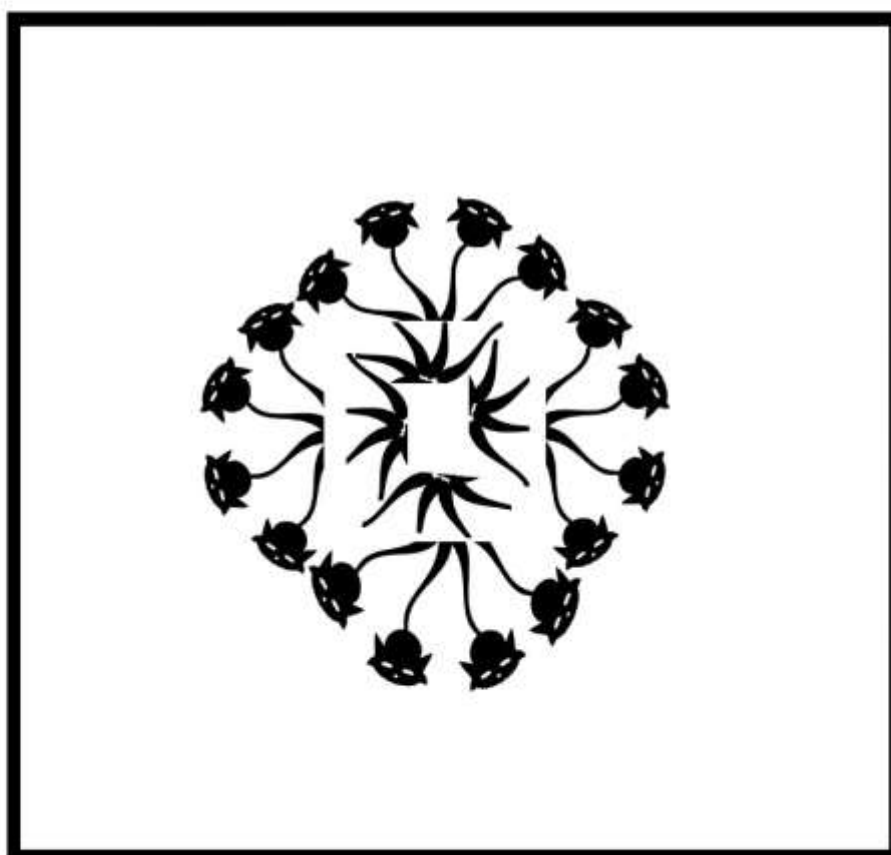

چرخش و انعکاس

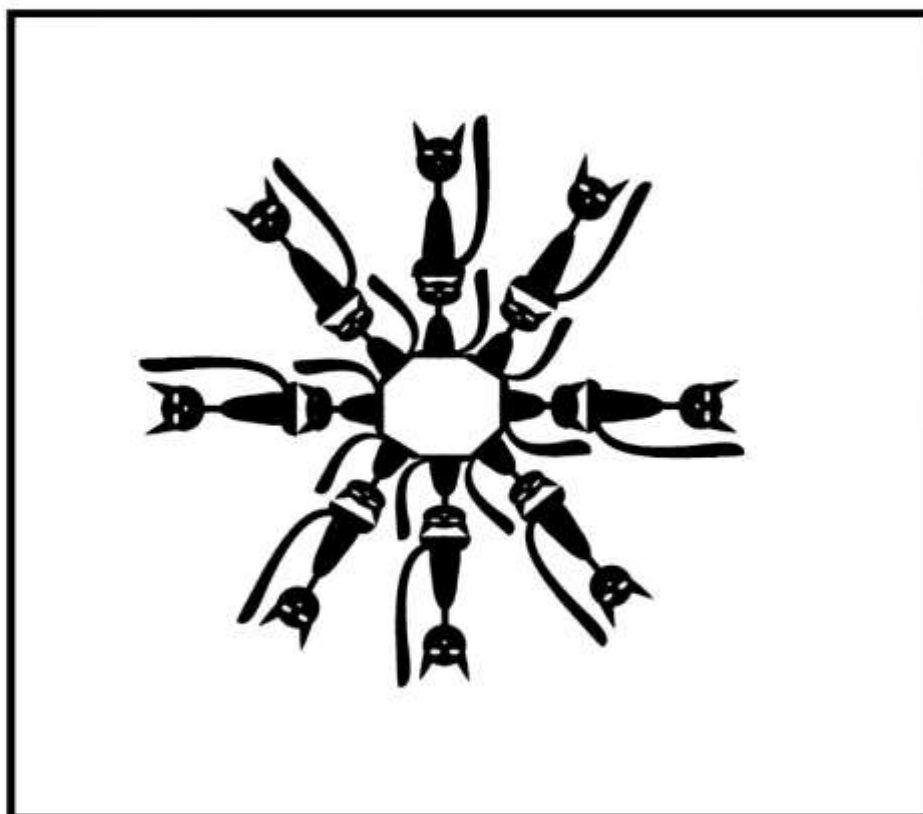

چرخش و اتساع



قطع خطوط ساختاری فعال

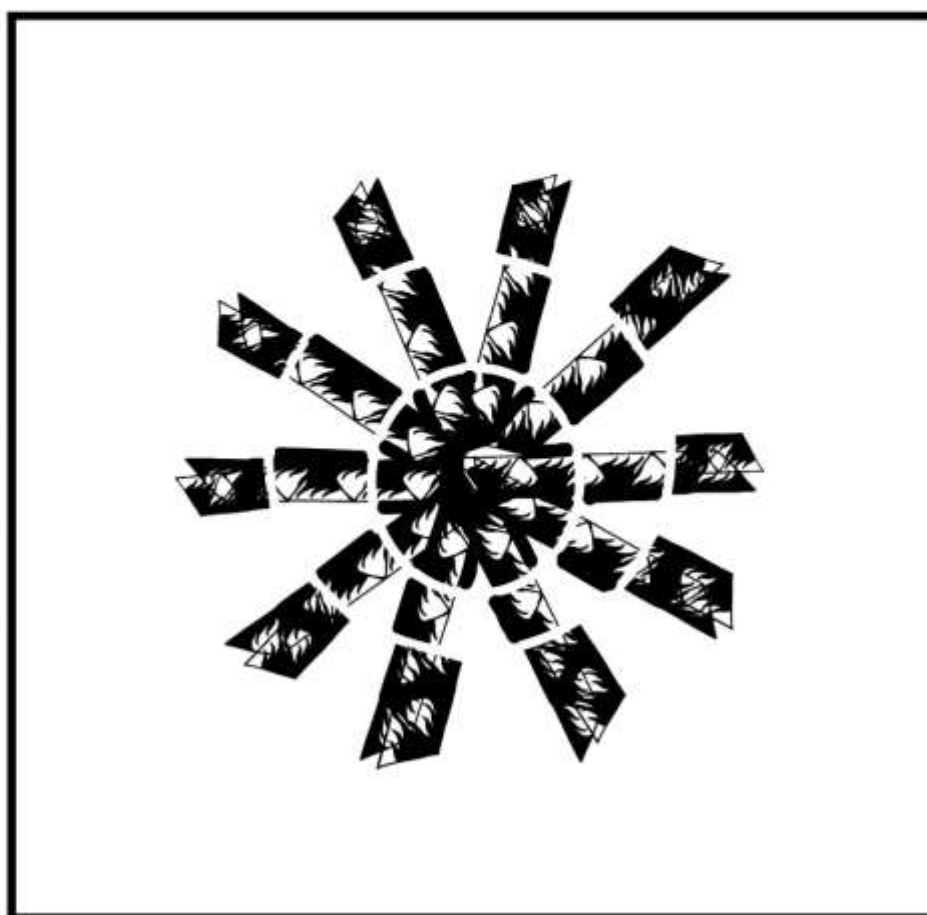



ترکیب بندی با:

تغییر
تاریخچه

تغیر تدریجی شکل

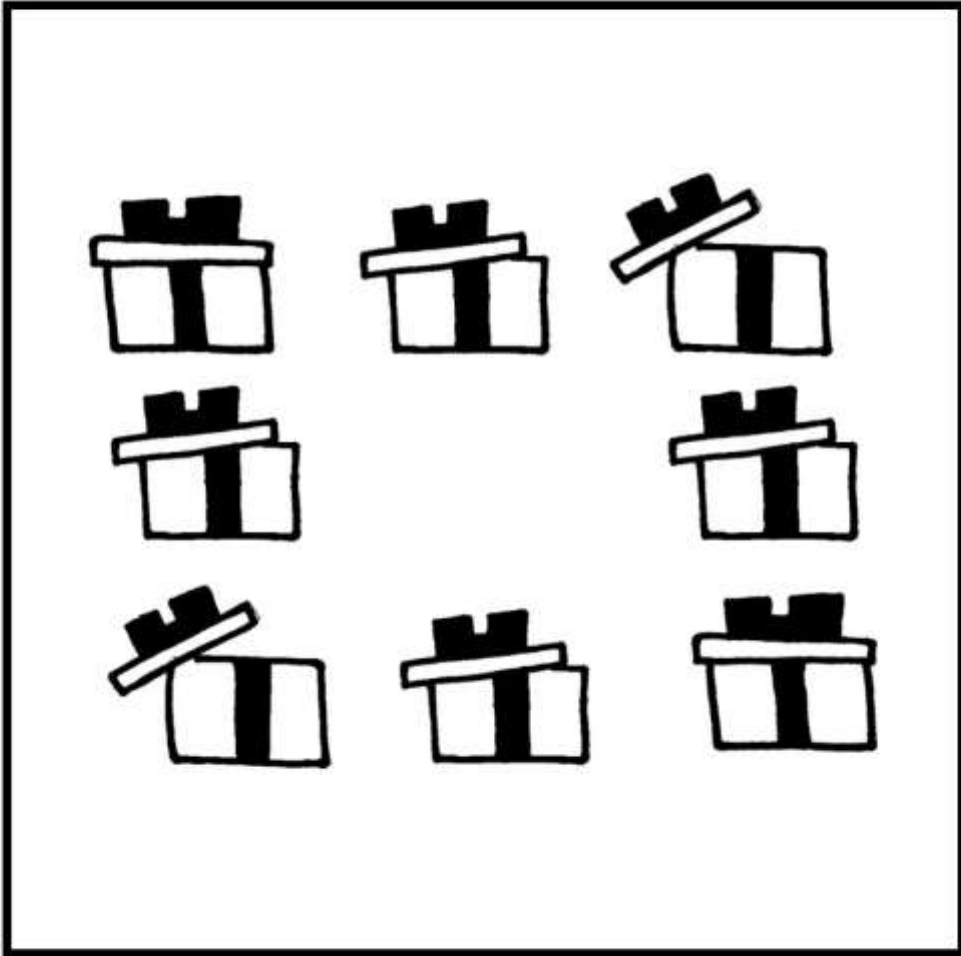

تغیر تدریجی شکل

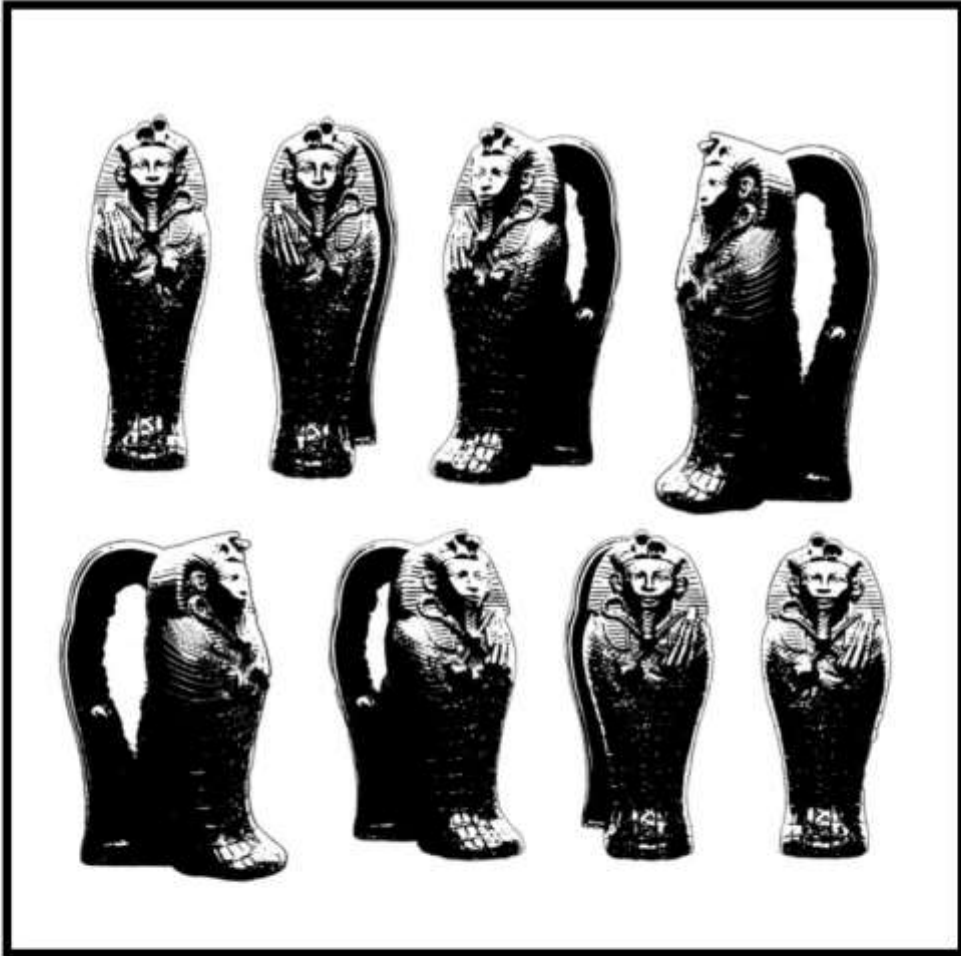

تغییر تدریجی اندازہ

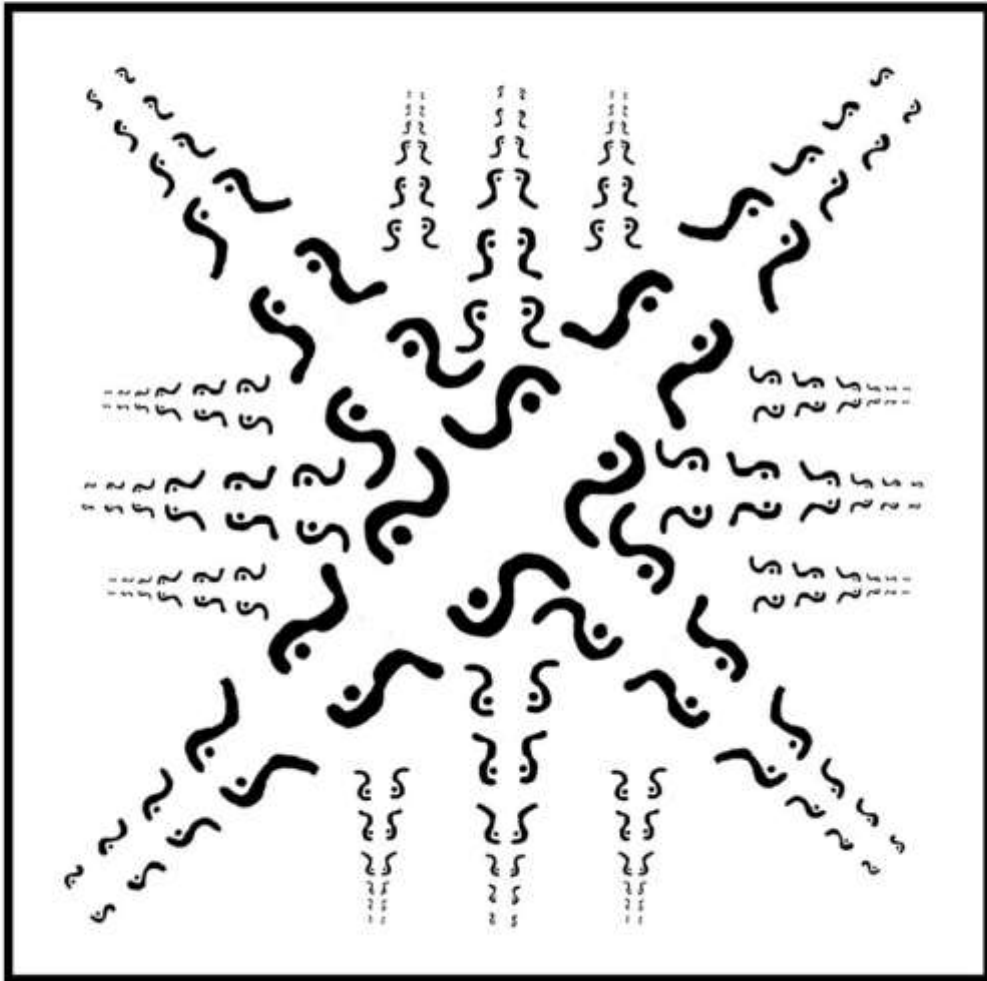

تغیر تدریجی موقعیت

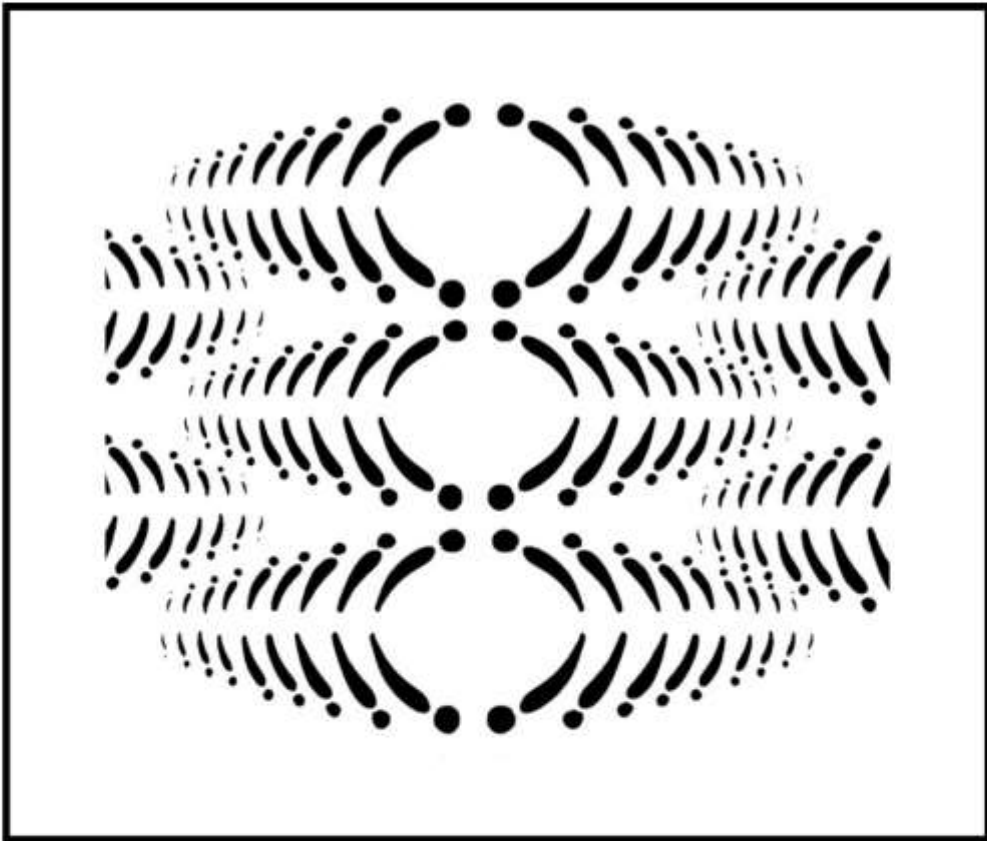

تغییر تدریجی جہت

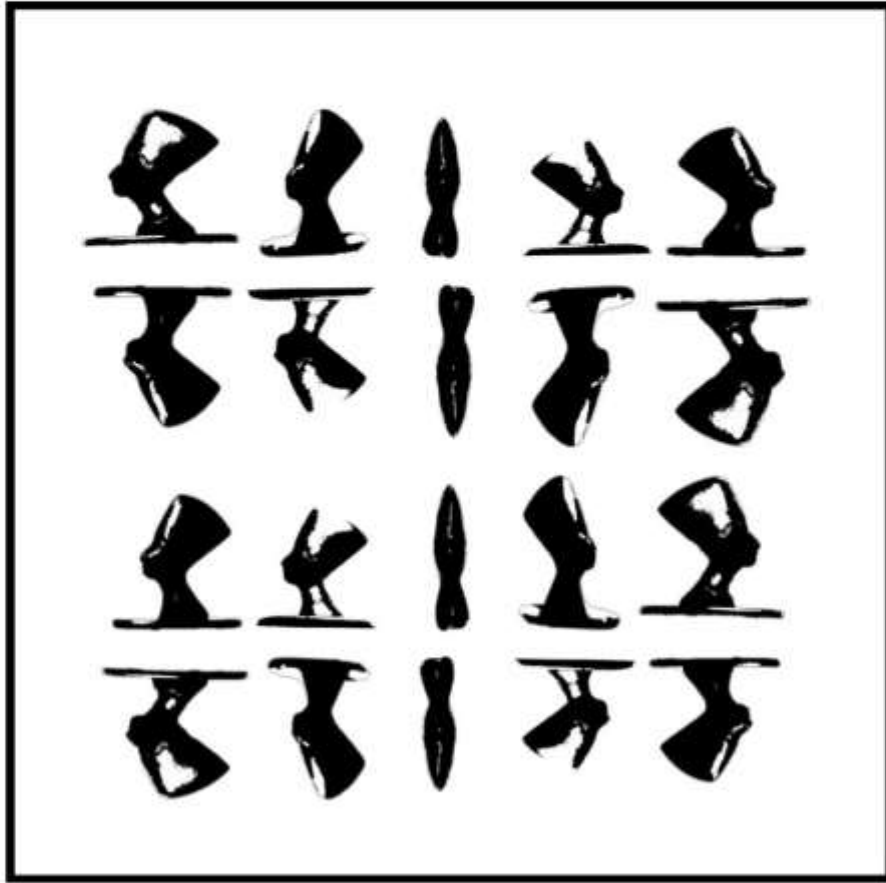

تغییر تدریجی نسبت ها

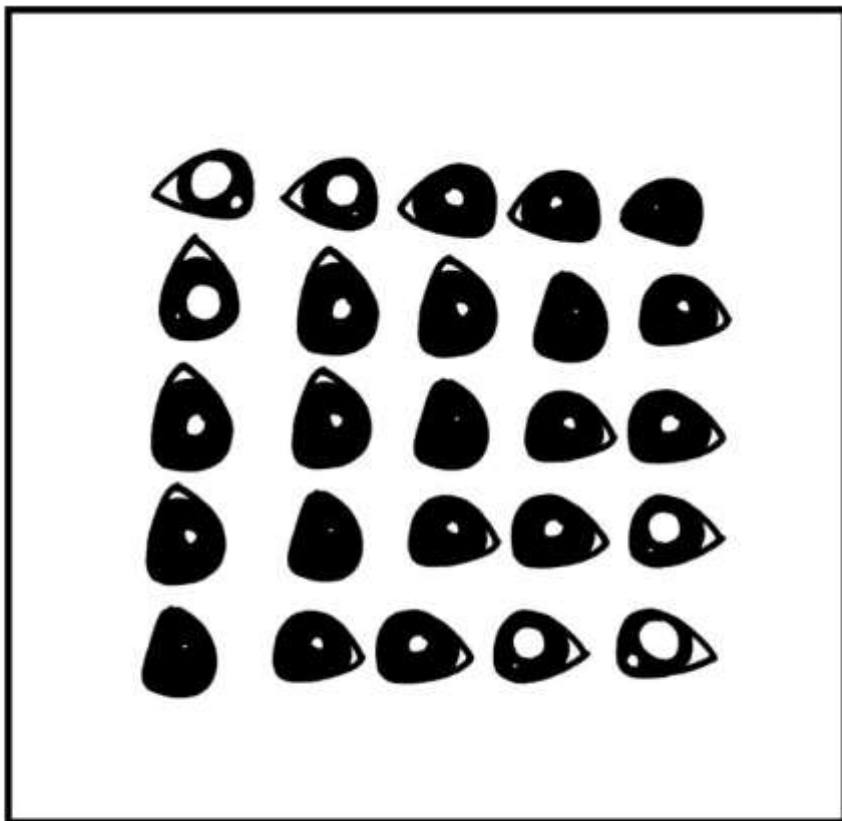

تَشَاوُحٌ



تشابه و شکل شعاعی

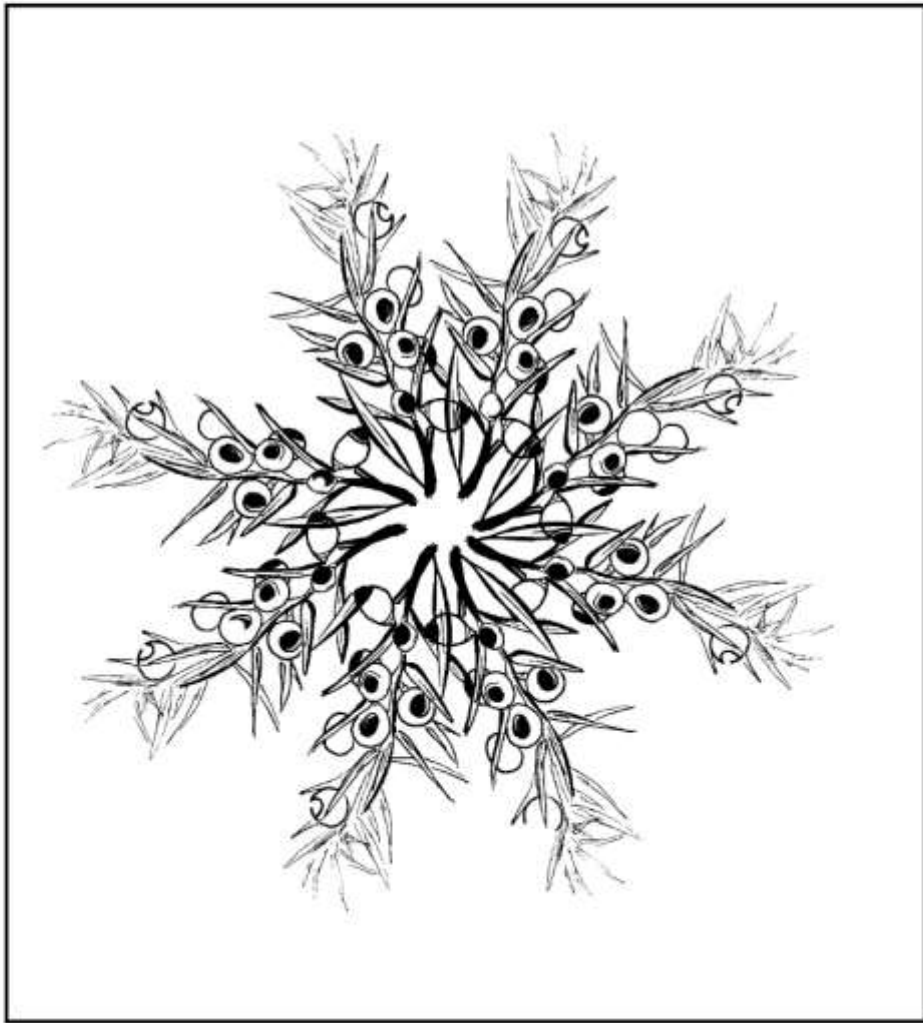

تشابه و تغییر تدریجی

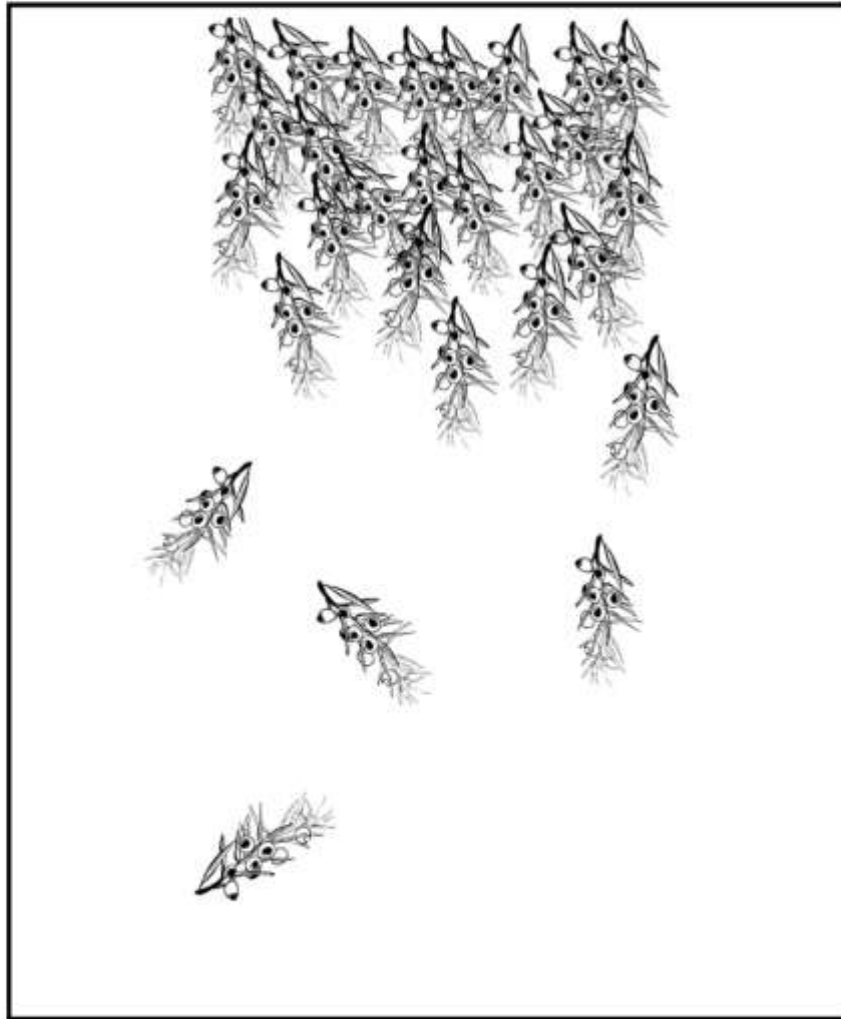

تشابه و تغییر تدریجی نسبت ها

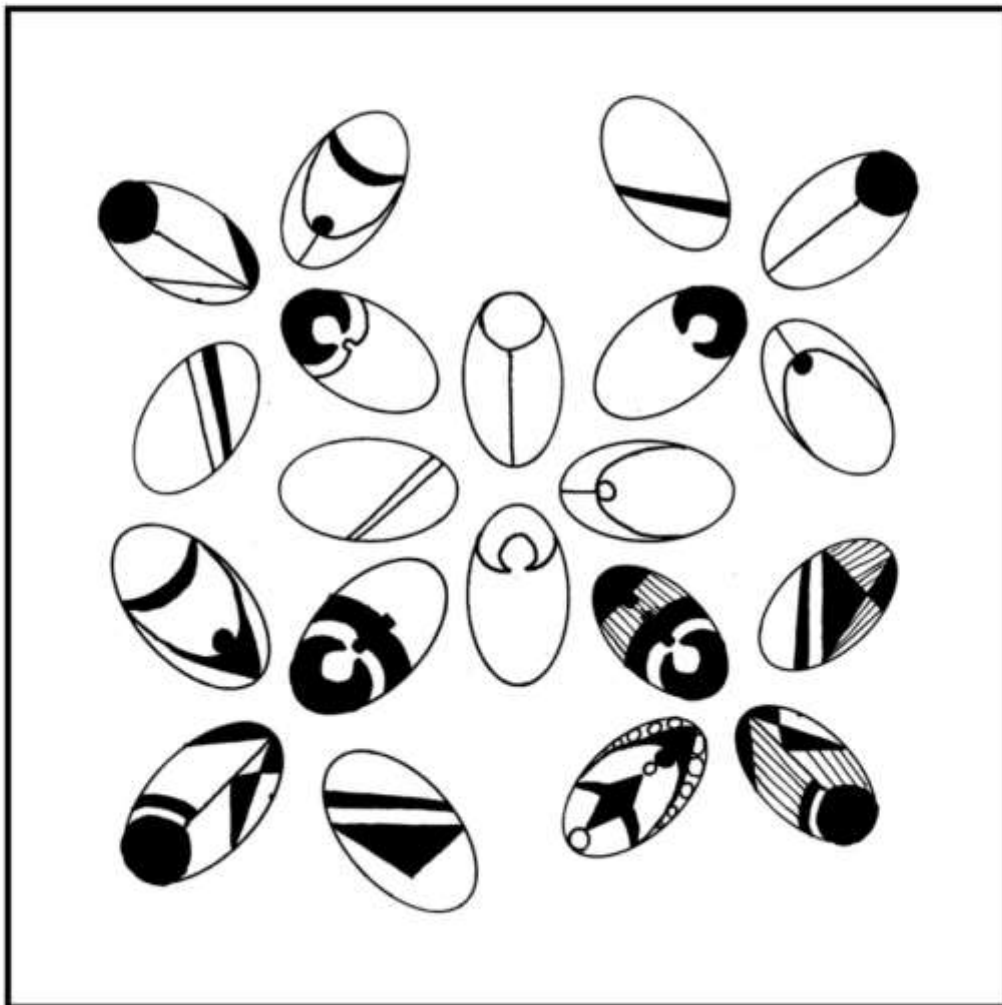

تمر گز



تمرکز نقطه ای

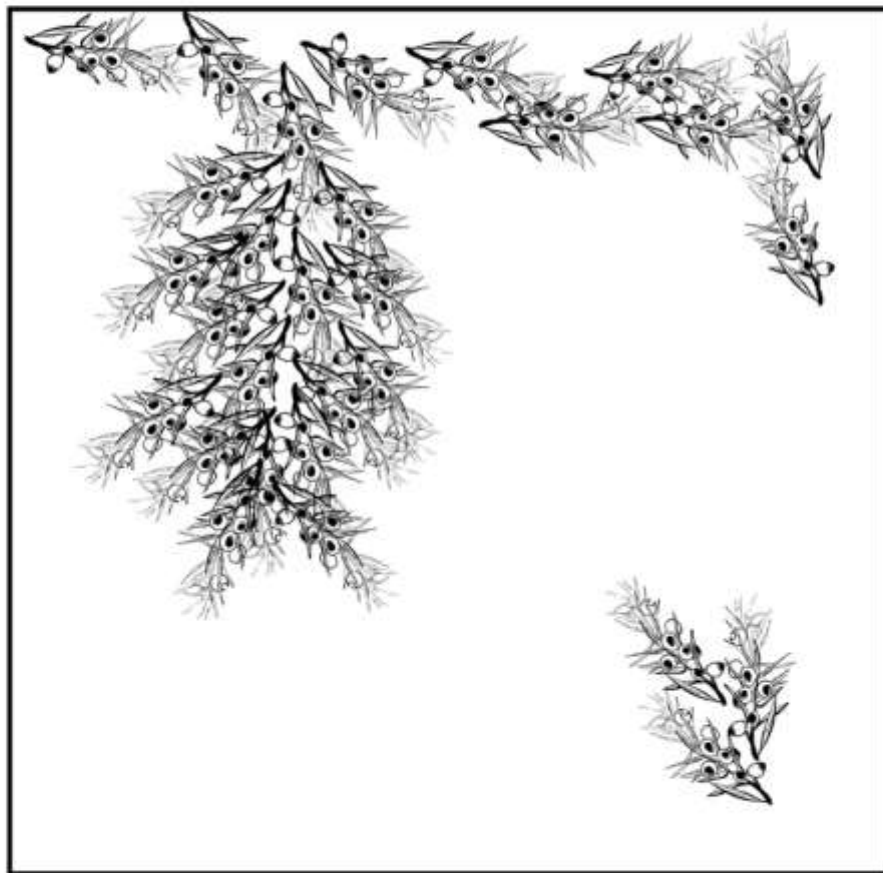

تمرکز خطی

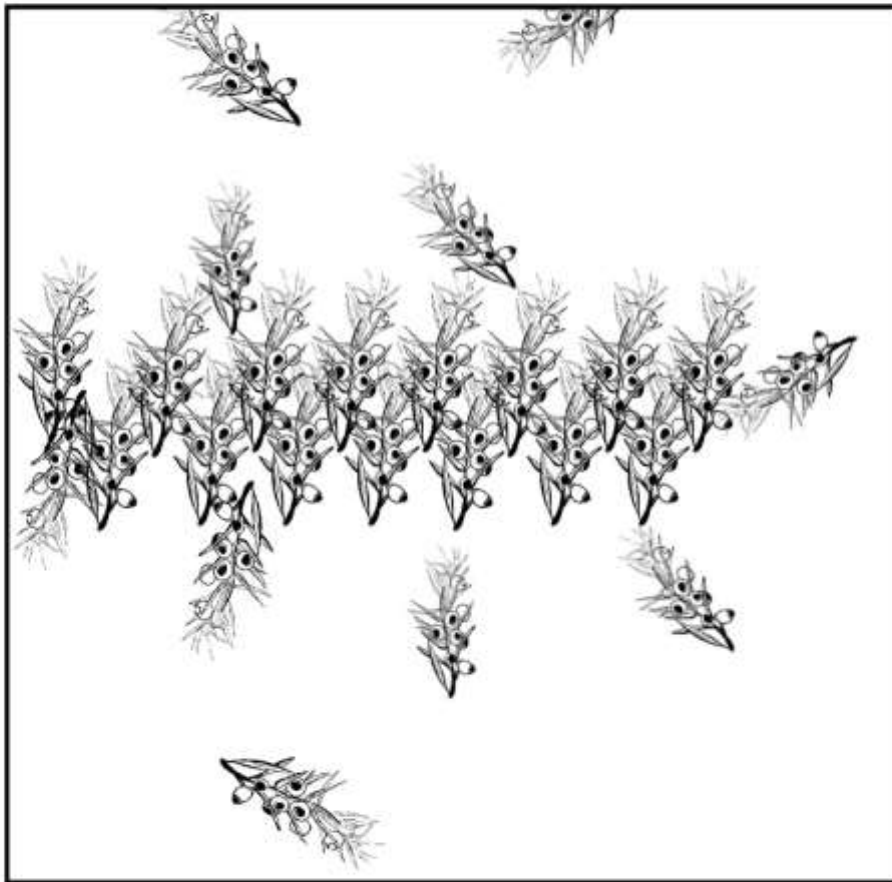

تمرکز سطحی





ترکیب بندی با:

تبیاین

تباين ظاهر

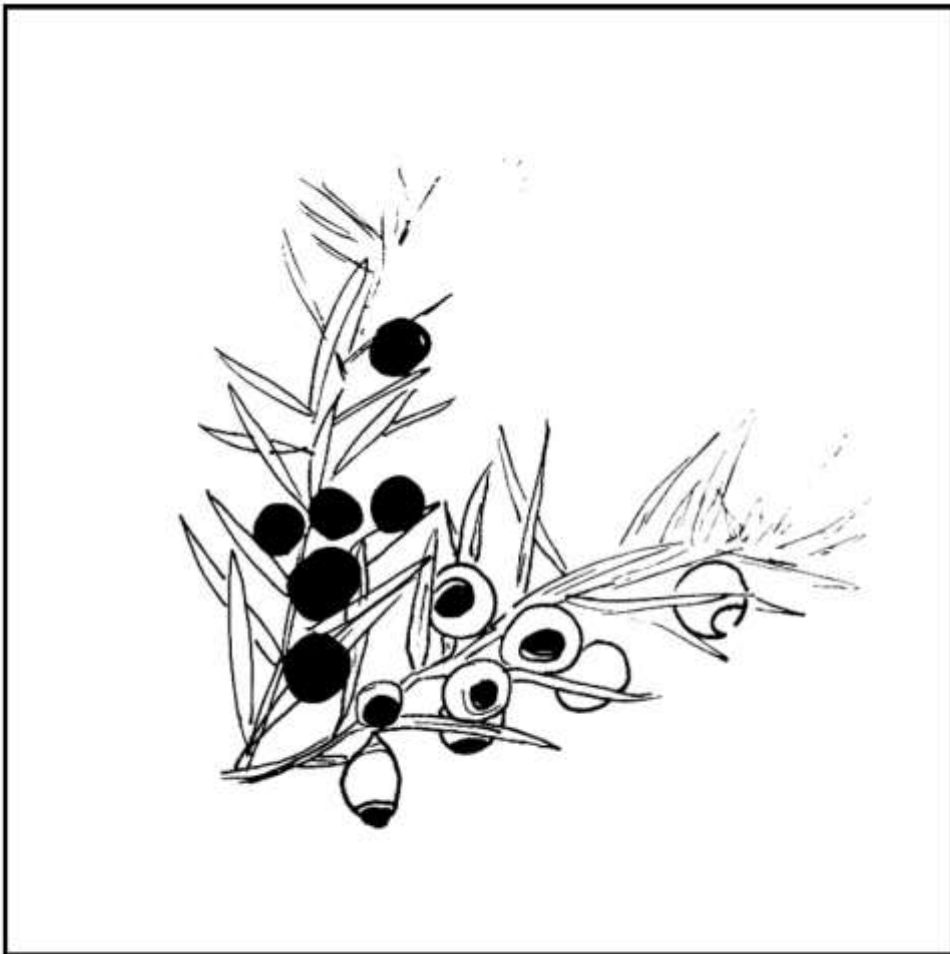

تباين مكانى

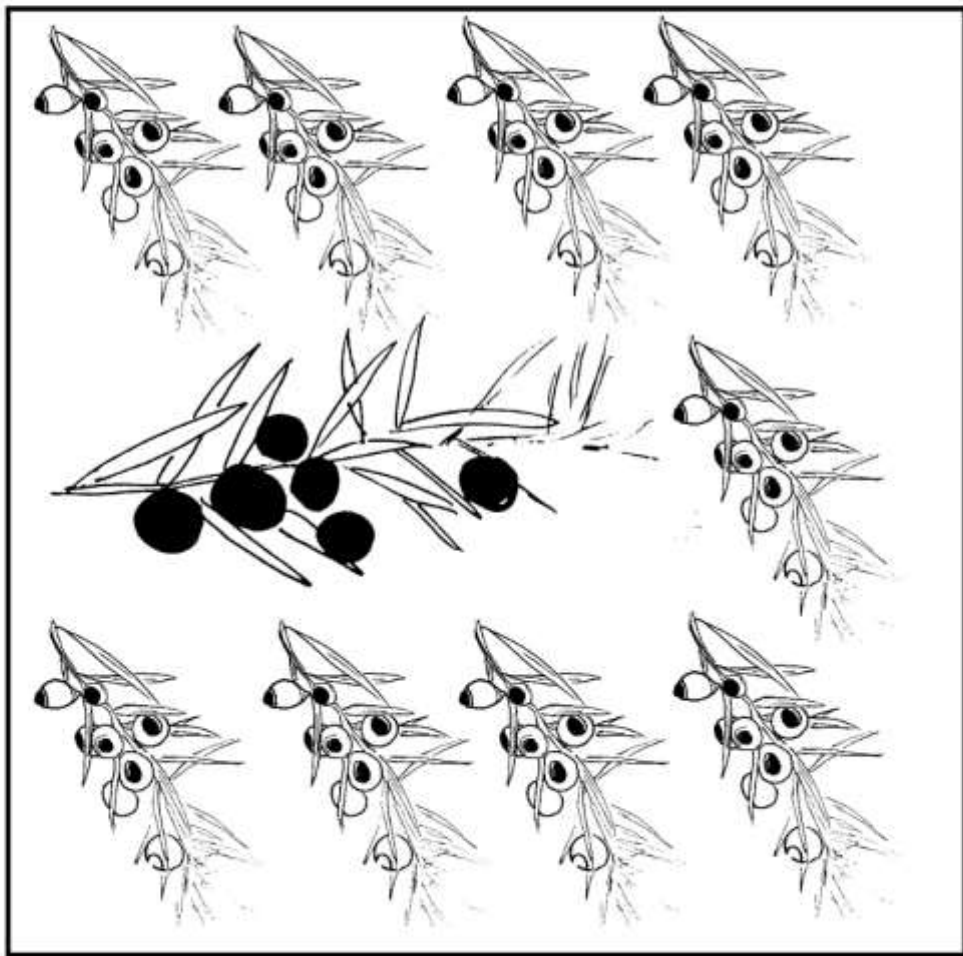

تباين در كميت

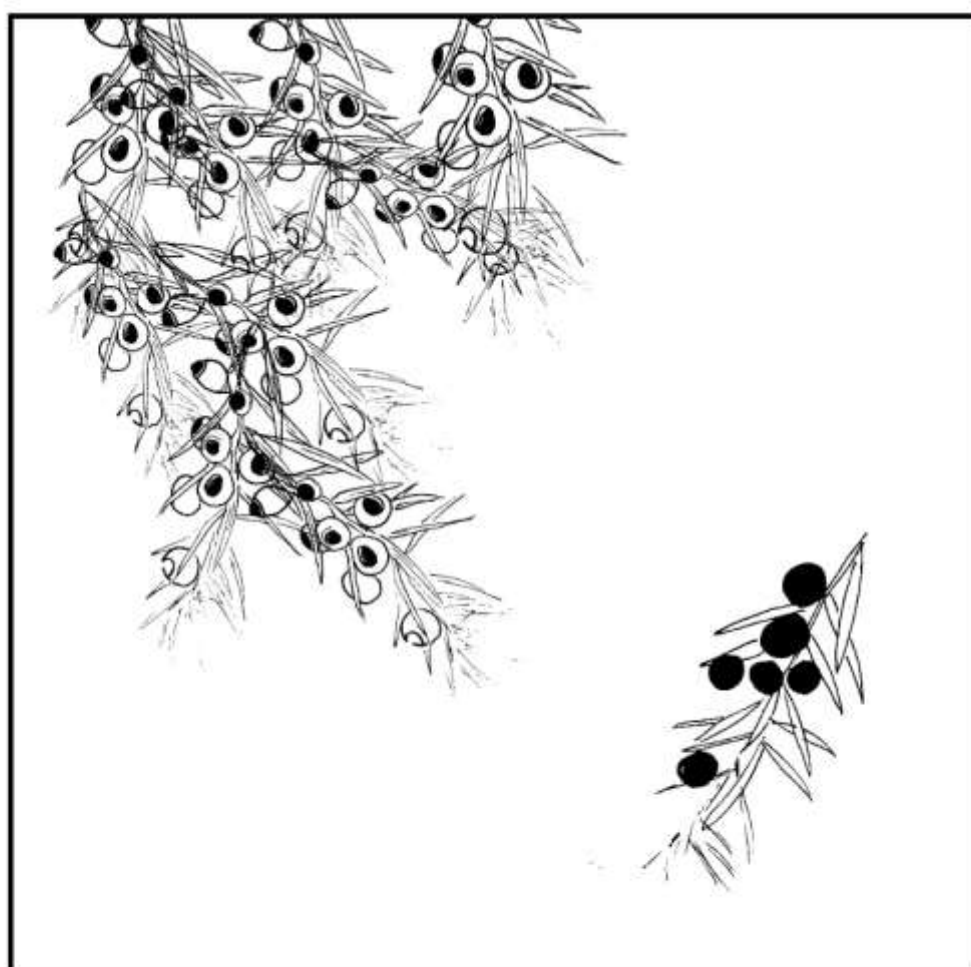

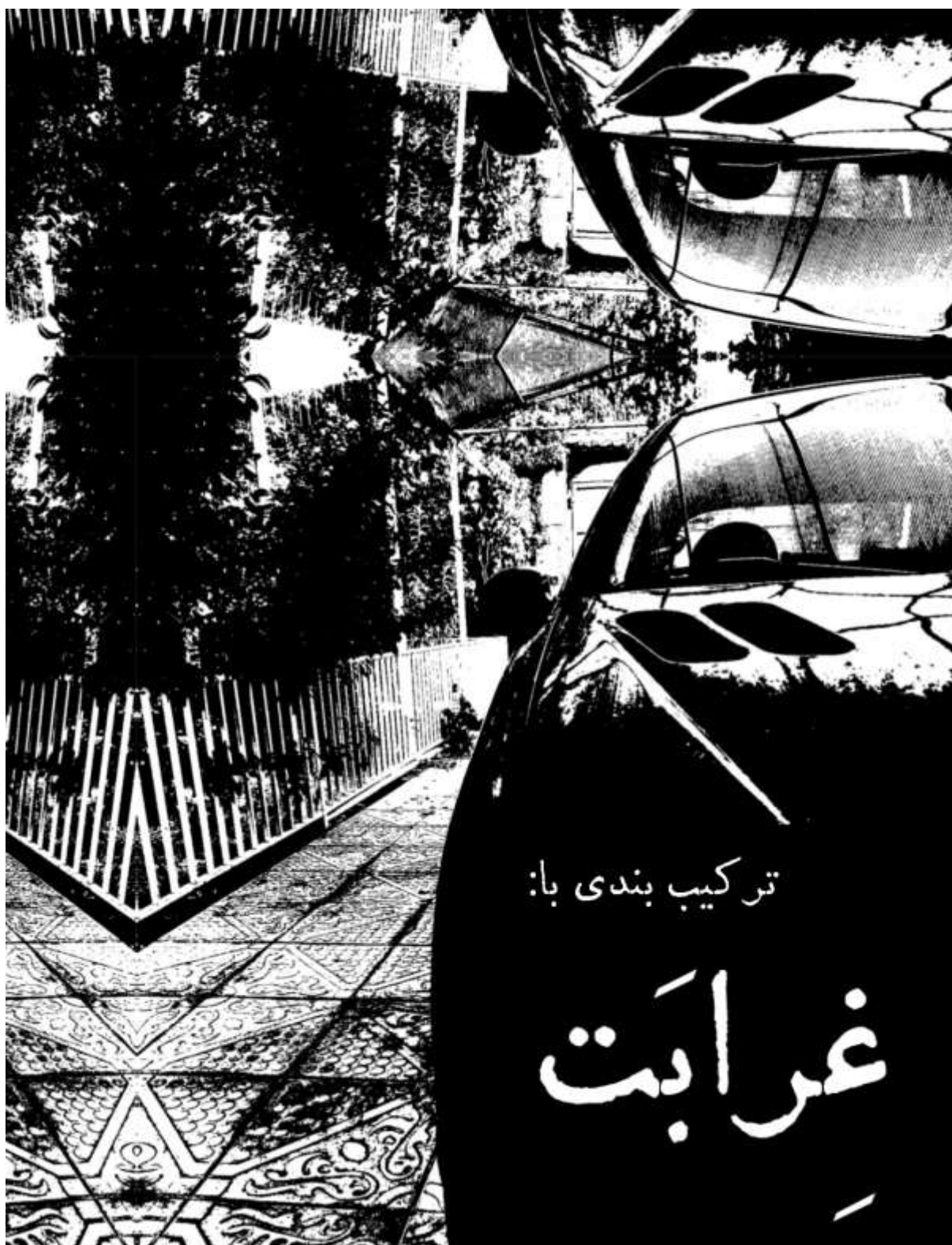

ترکیب بندی با:

غرابیت

غرابت در شکل

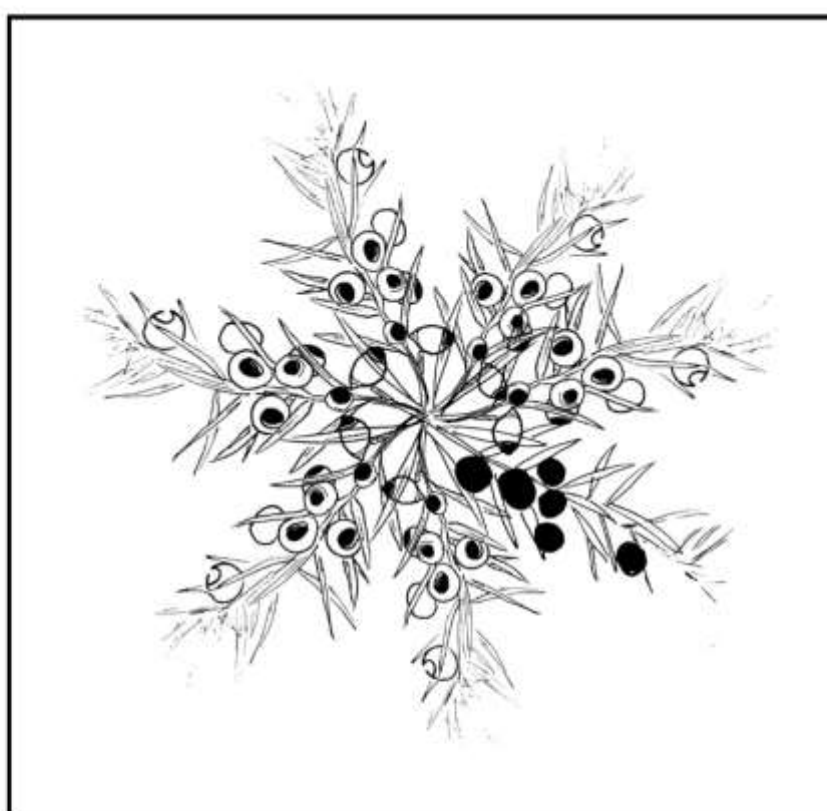

غرابت در اندازه

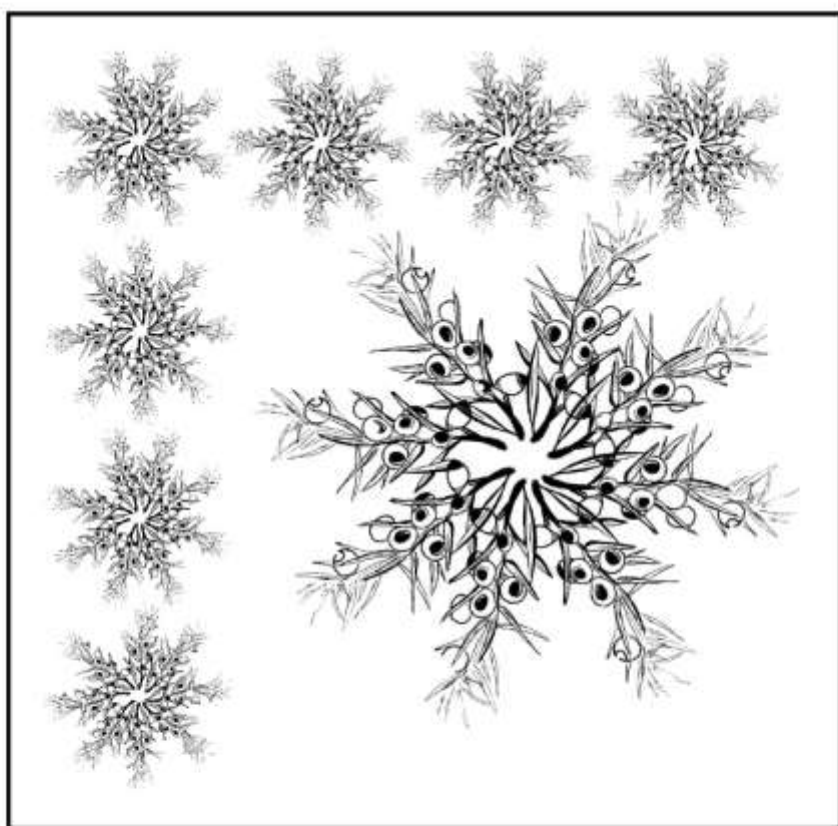

غرابت در رنگ

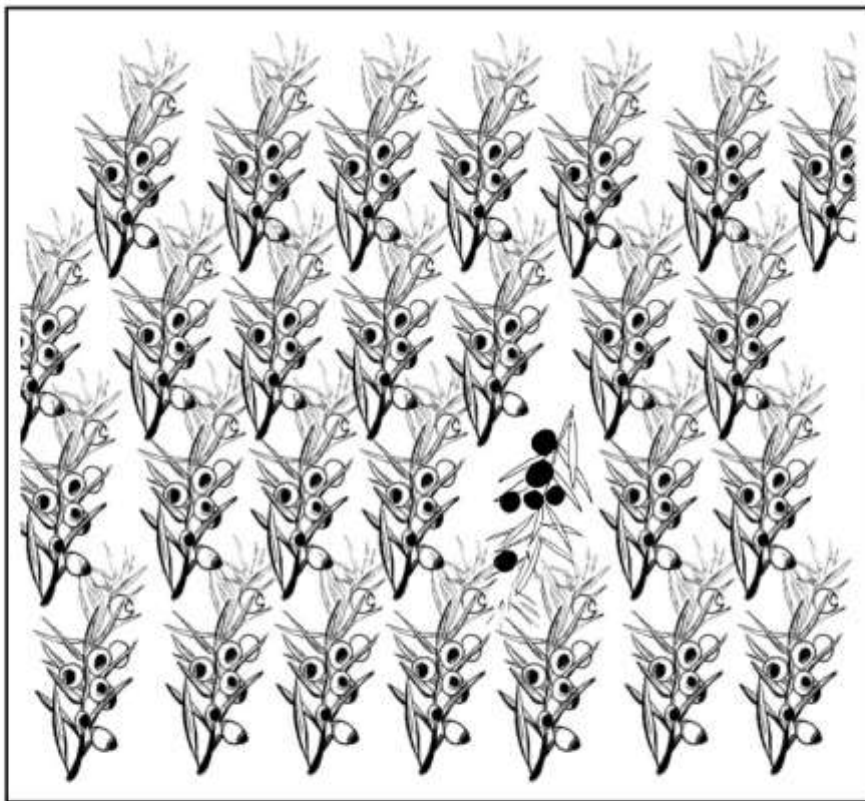

غرابت در بافت

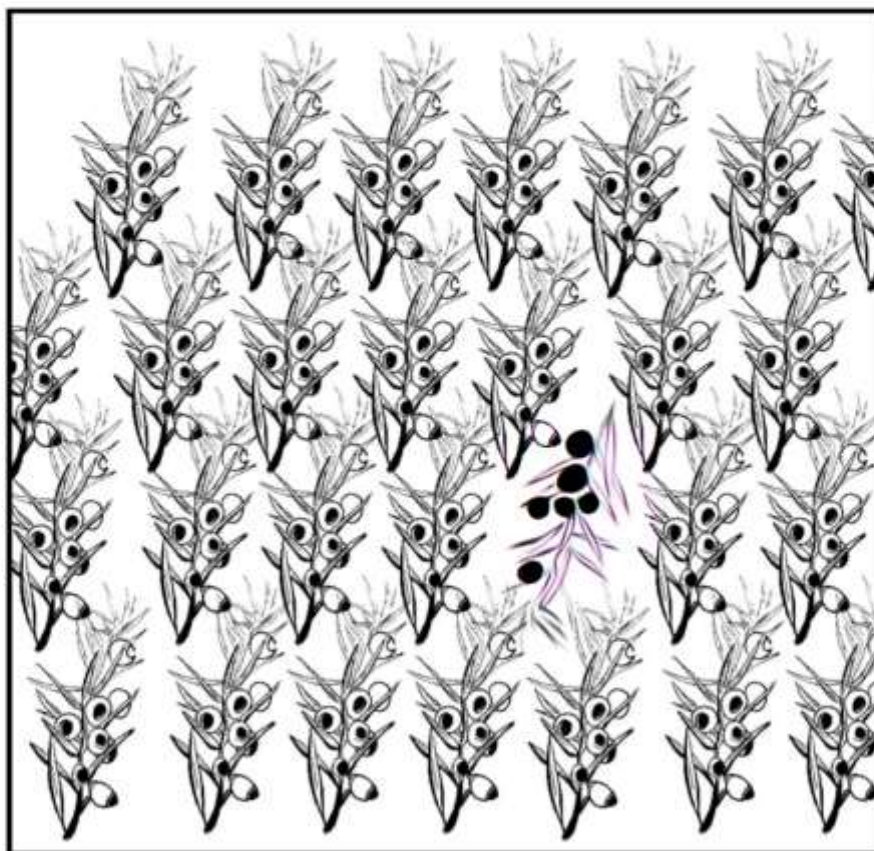

غرابت در موقعیت و جهت

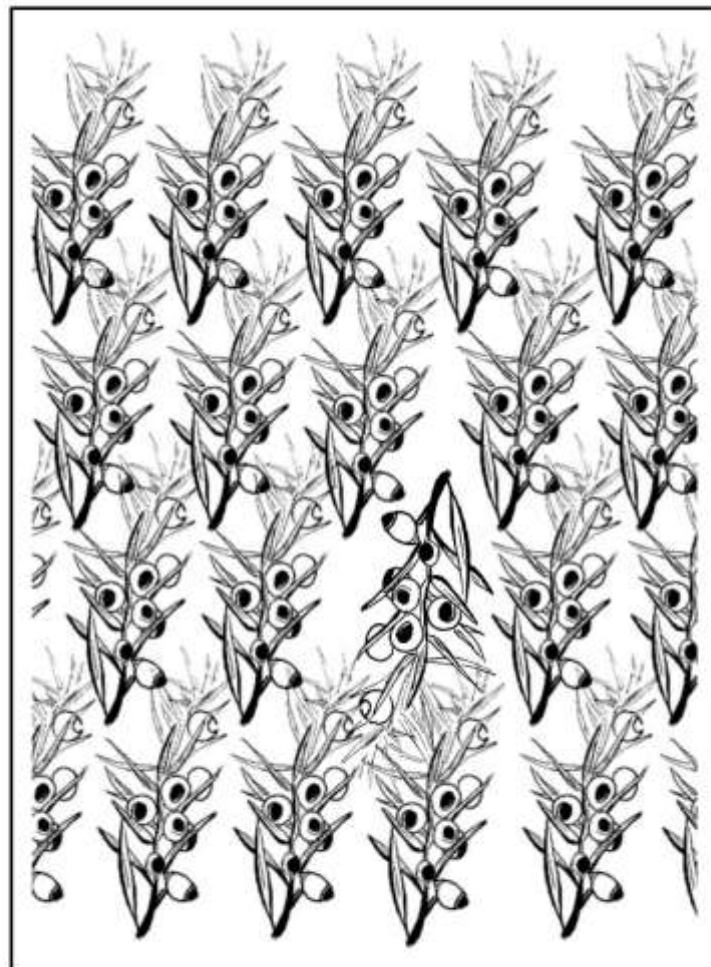



فرم طبیعی ریتم یکنواخت

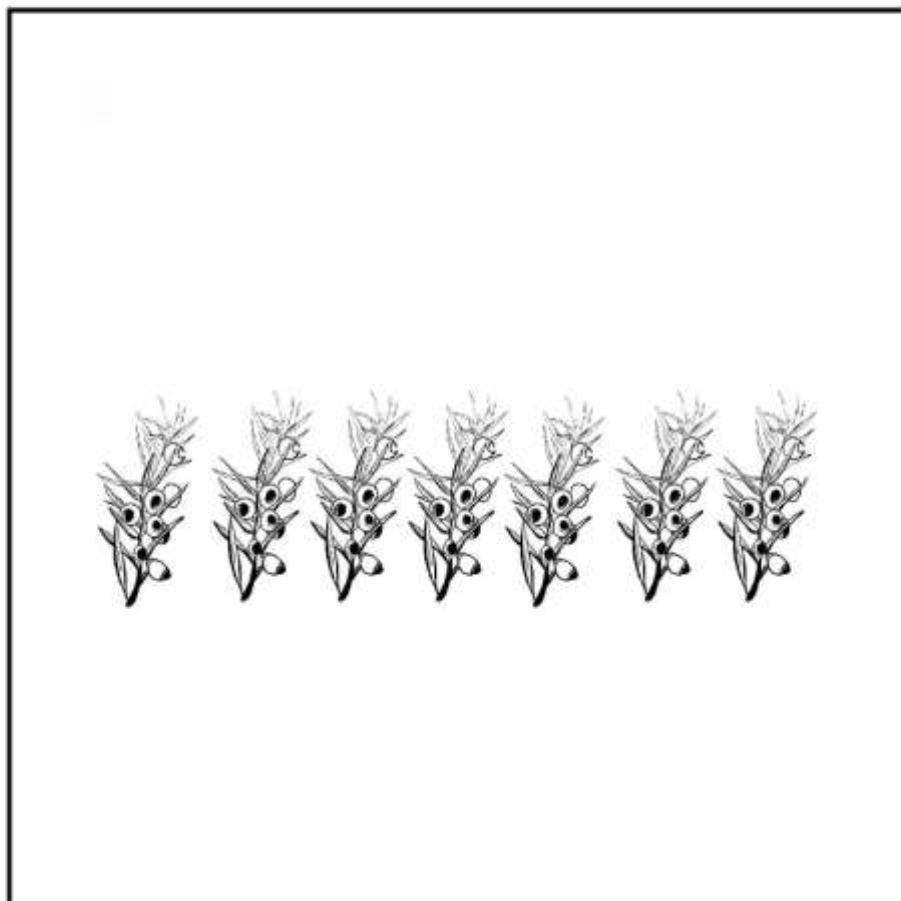

فرم طبیعی ریتم متناوب

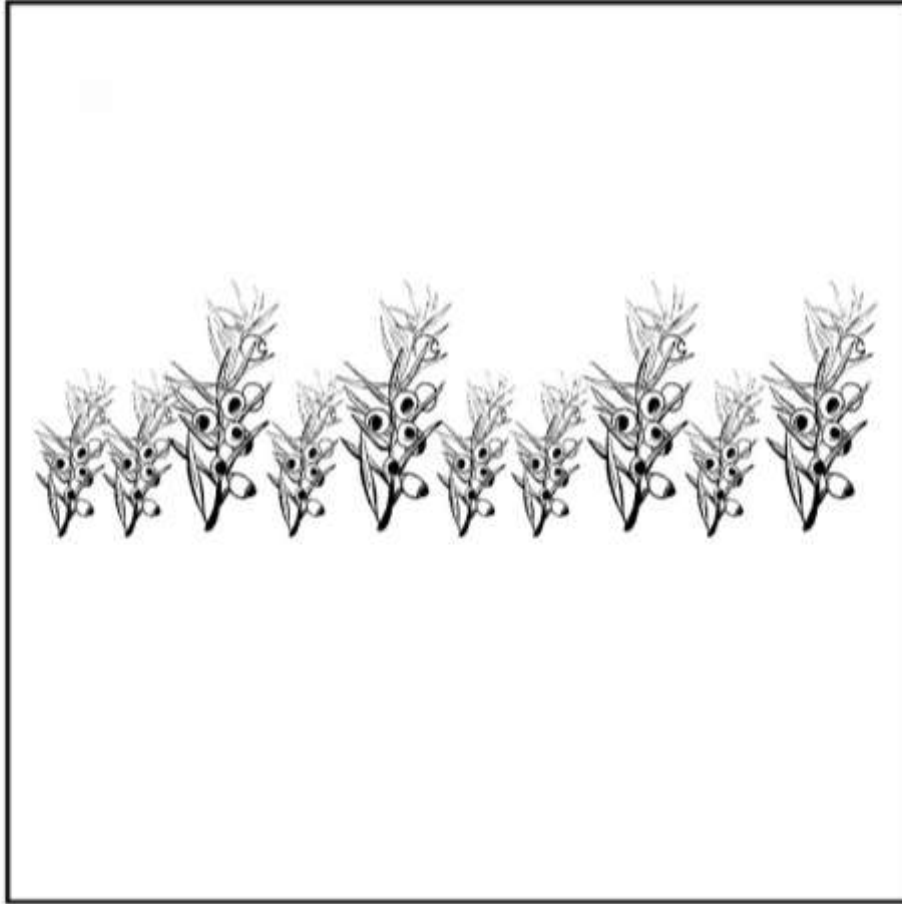

فرم طبیعی ریتم تکاملی

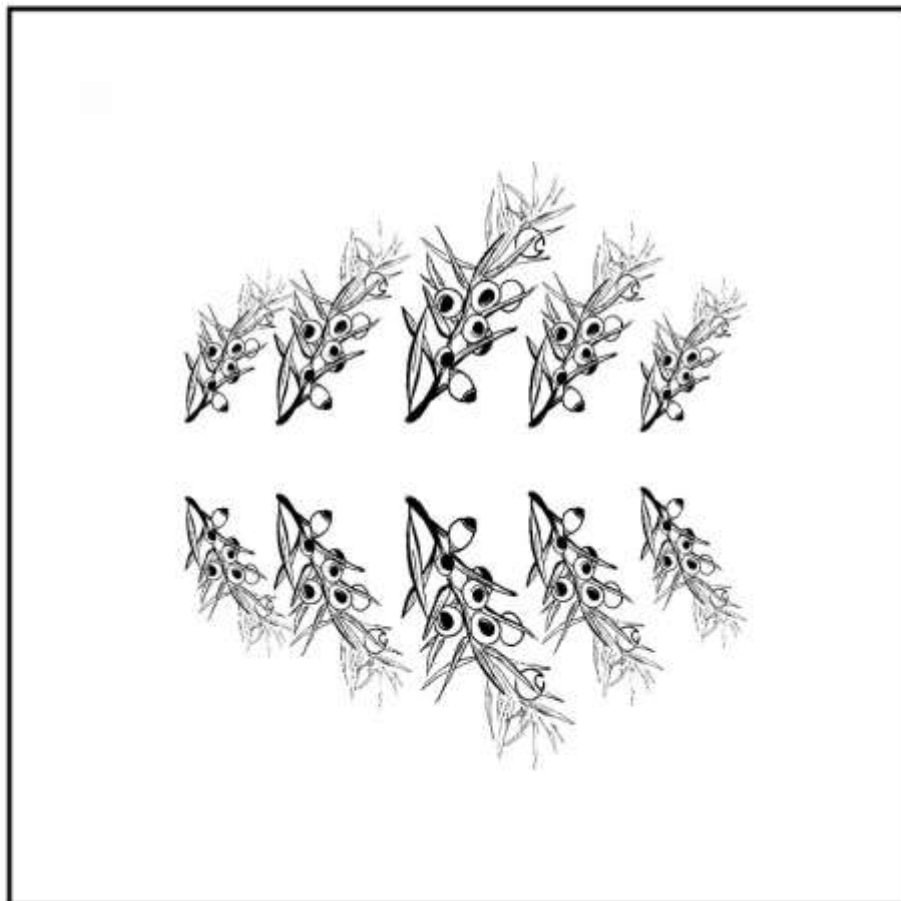

فرم طبیعی ریتم موج

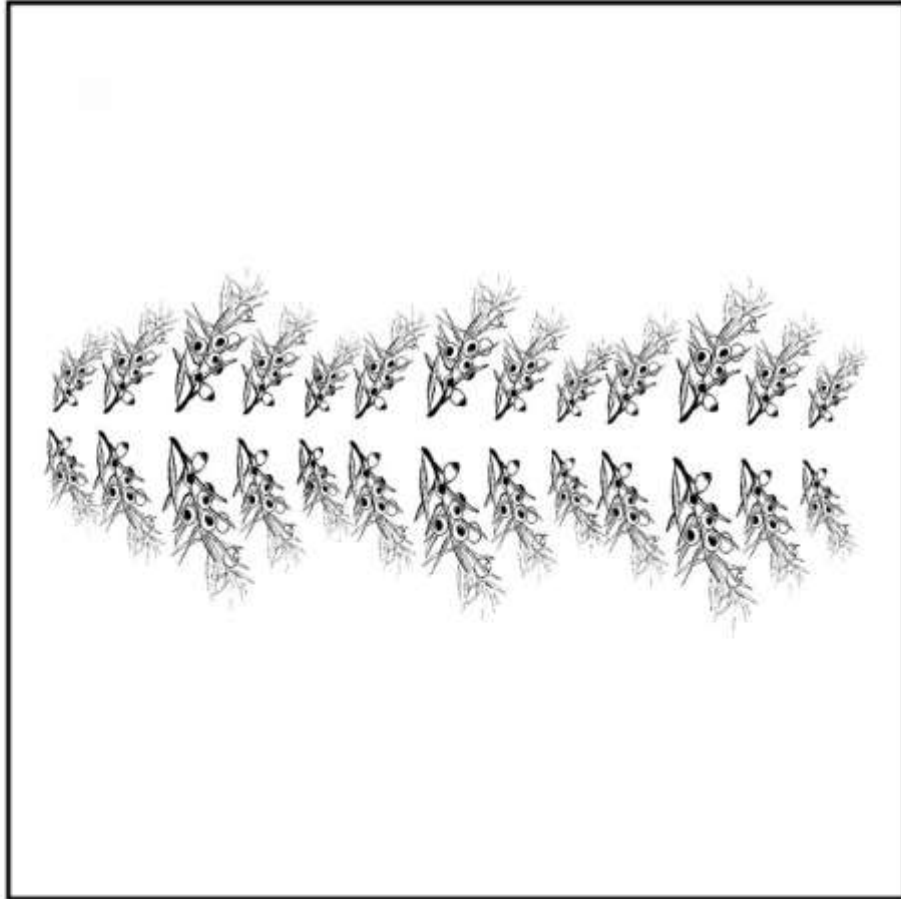

فرم زبانی ریتم یکنواخت

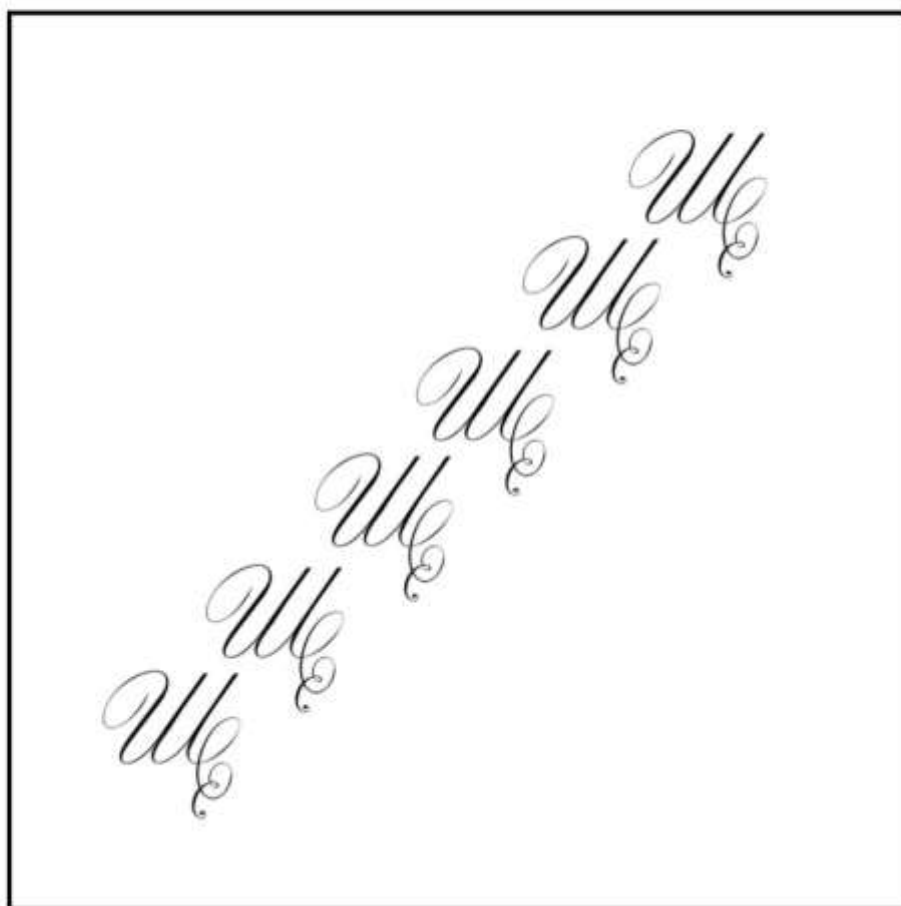

فرم زبانی ریتم متناوب

U U U U U

فرم زبانی ریتم تکاملی



فرم زبانی ریتم موج

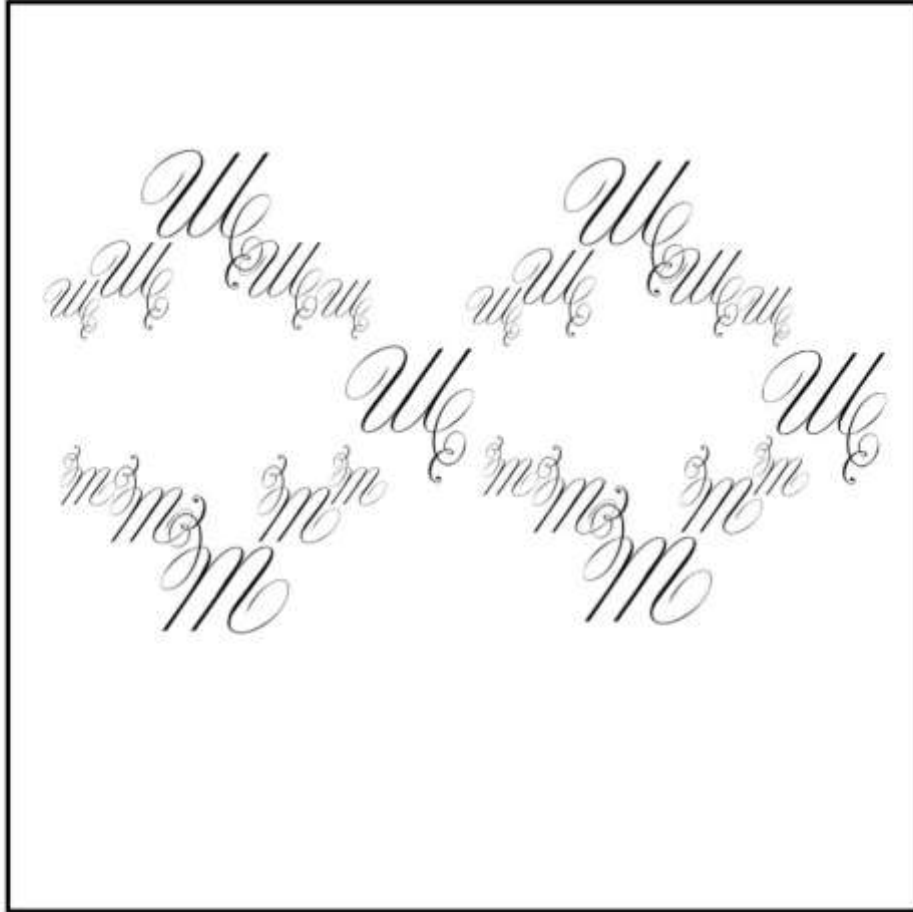

بافت



بخش یک.

ایجاد بافت با دست



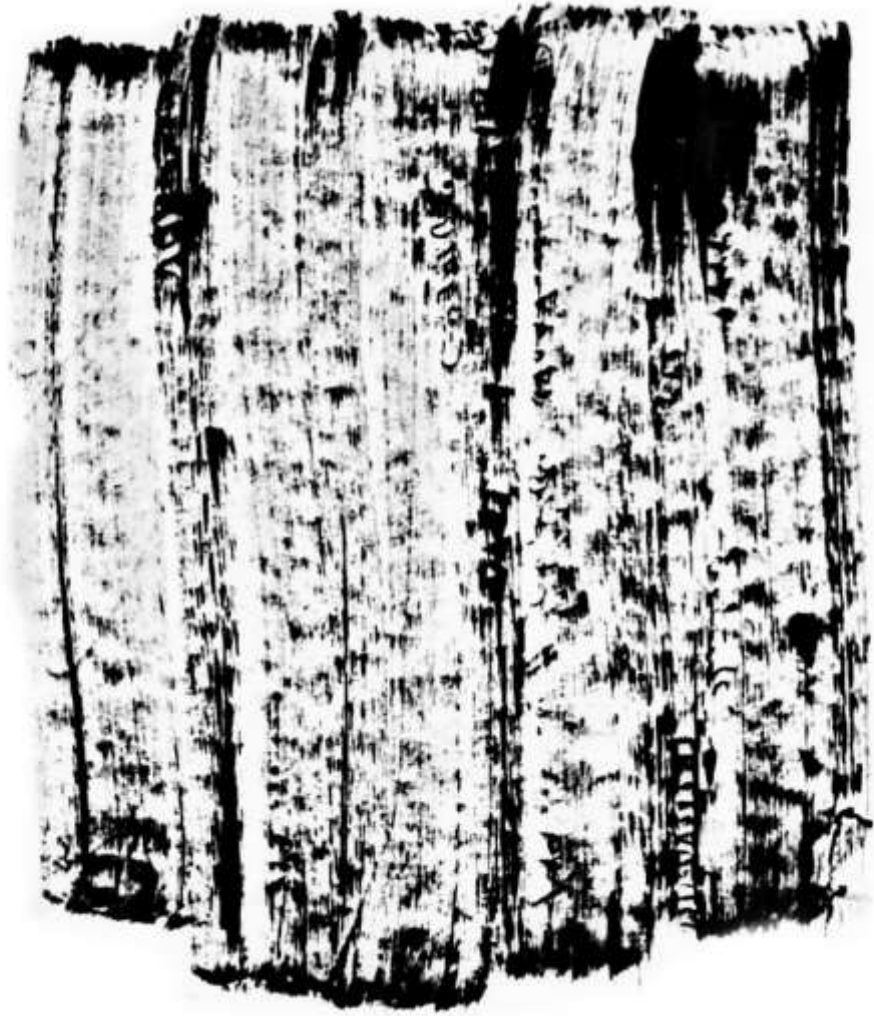

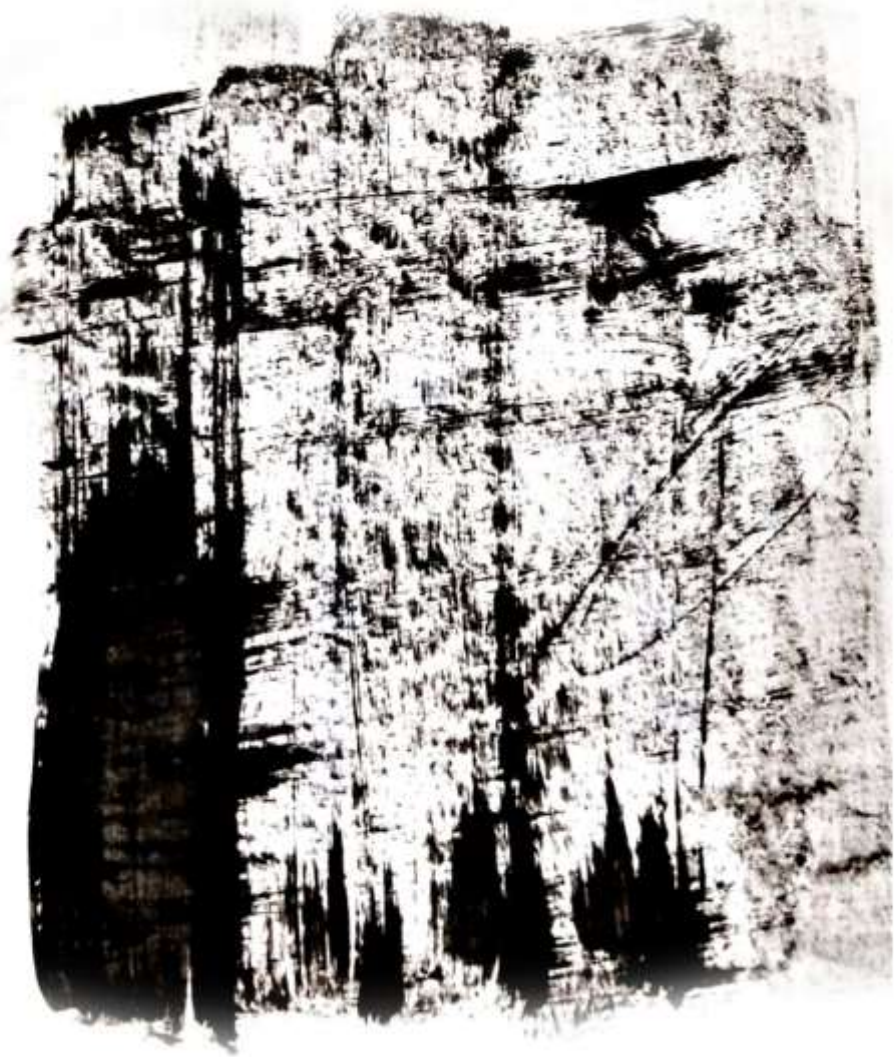



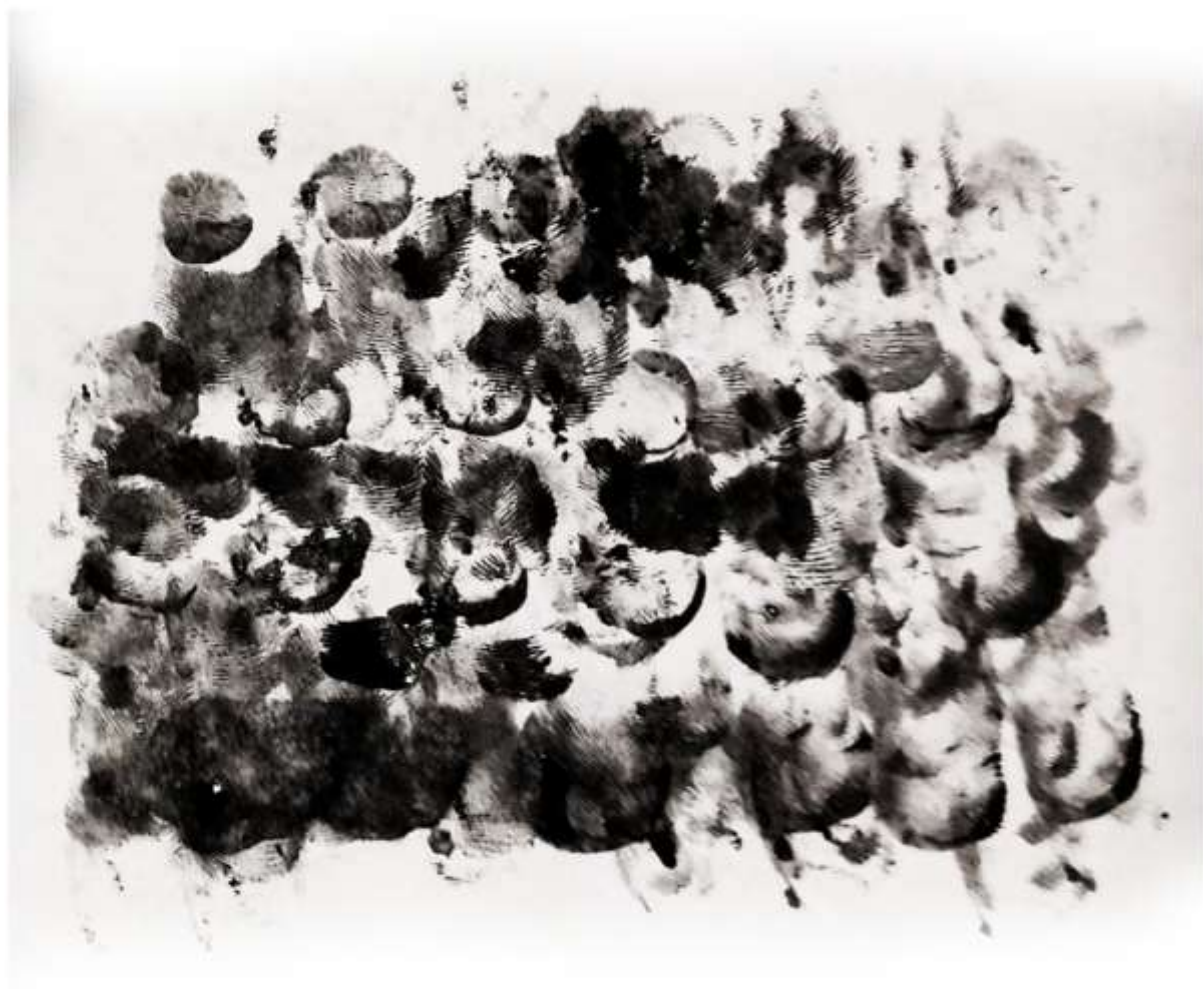



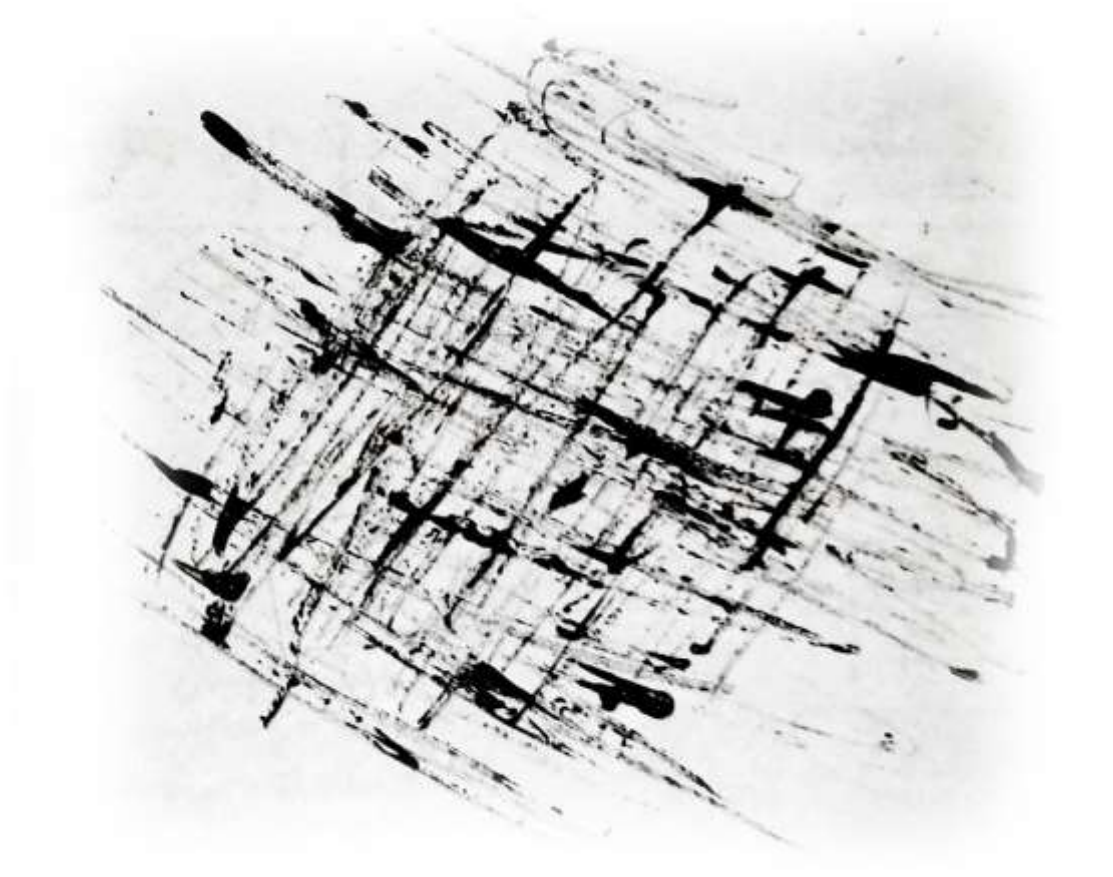













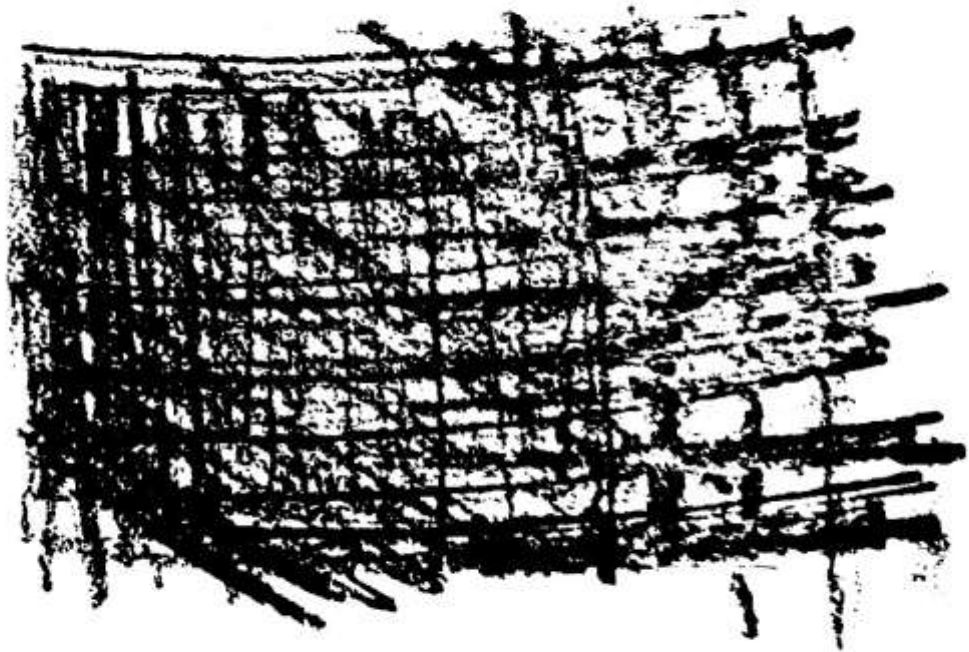





شناسنامه کارها



گواش. قلم مو بر کاغذ

گواش. سرانگشت بر کاغذ

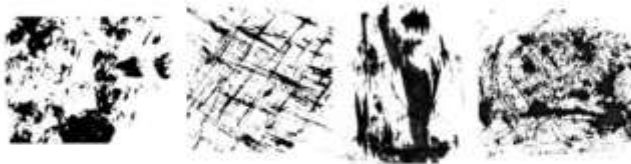

گواش. تکه چوب بر کاغذ

گواش. تکه چوب بر کاغذ مجاله

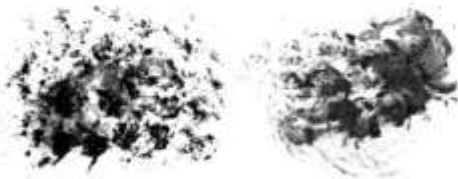

گواش. دستمال کاغذی بر کاغذ

گواش. قلم مو بر دستمال کاغذی

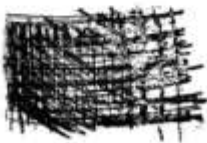
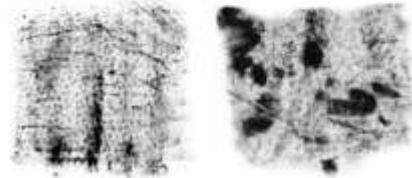

مداد B6. بر کاغذ

عکاسی + گواش و قلم مو بر عکس چاپ شده



بخش دو.

عکاسی از بافت ها

بافت در آشپزخانه



شکر



پوست هلو



جو پیرک



شاه توت



درون پوست گوجه

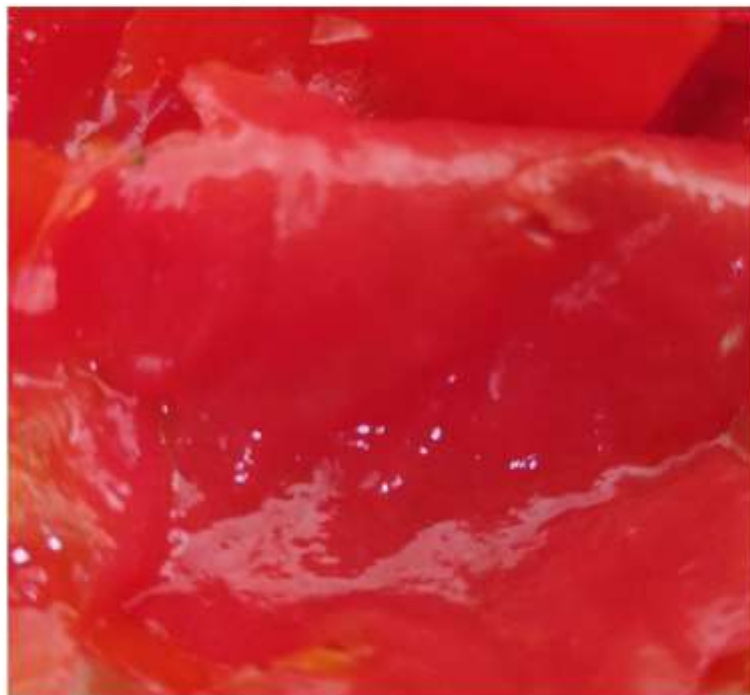

حصیر



خز پوست گریه



فرش



چای در لیوان

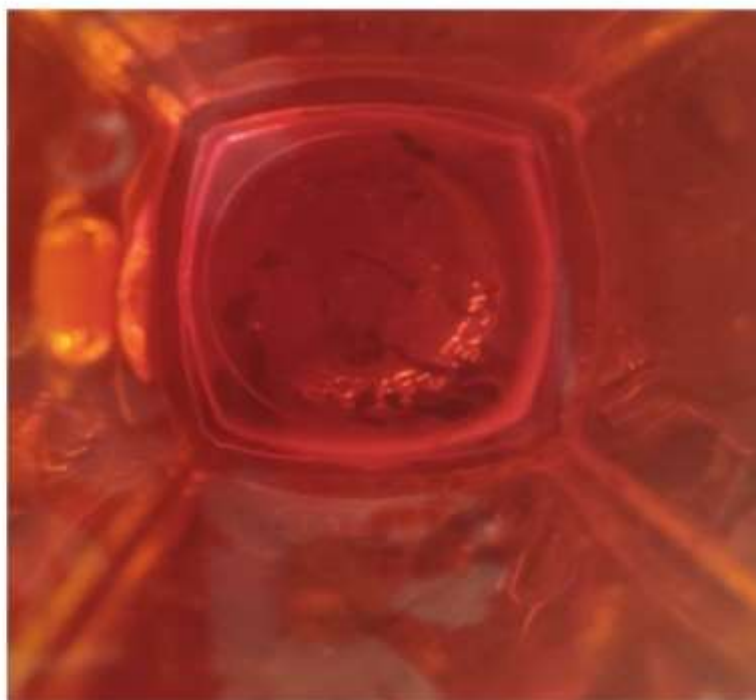

ام دی اف مثلاً طرح چوب



پشت فرش ماشینی

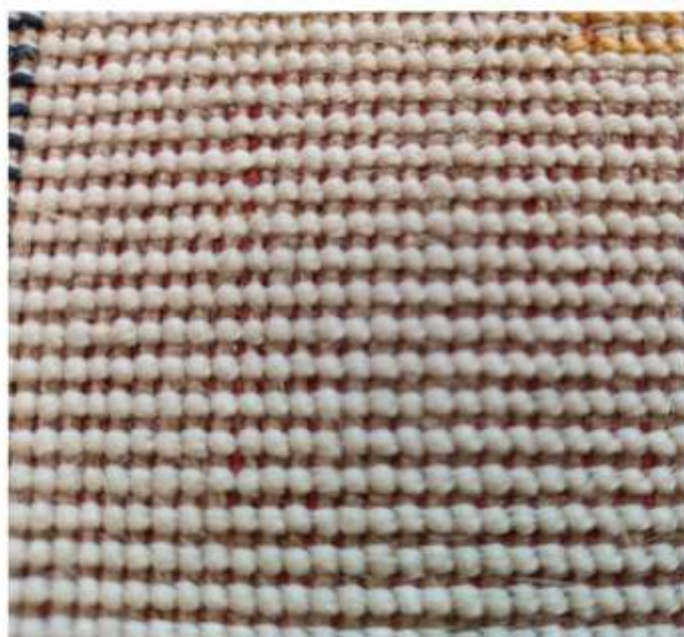

روپہ صندوقی



سەبۇنلار



پارچه ماسک



پتو



مواد نور



جایی از خانه

که یادم نمیدان کجا بود

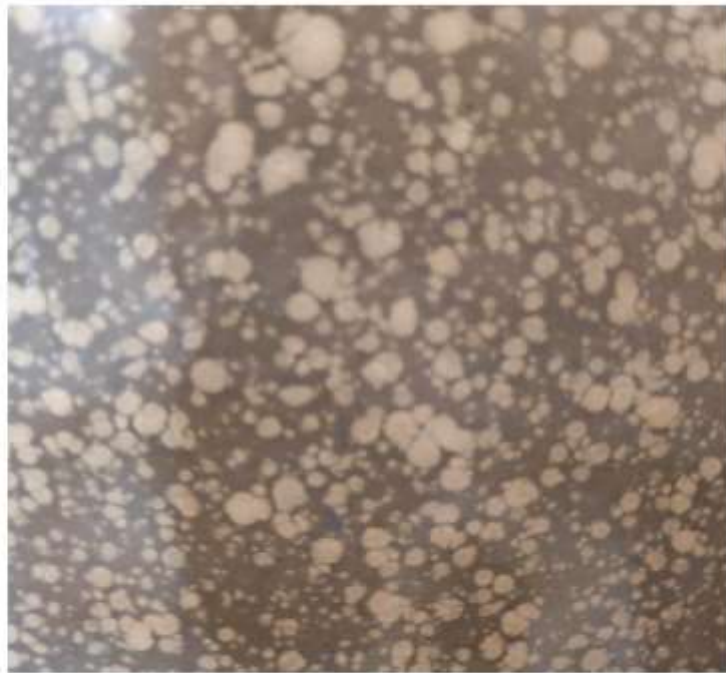

بافت در حیات



پرزیت در خاک



گل توری



درون تنه خشکیده درخت



سطح استخر برگ گرفته



تار عنكبوتی پر از شکار روی میله آهنی کمی زنگ زده



جلوی کفش اکیلی



ورق پلی کربنات

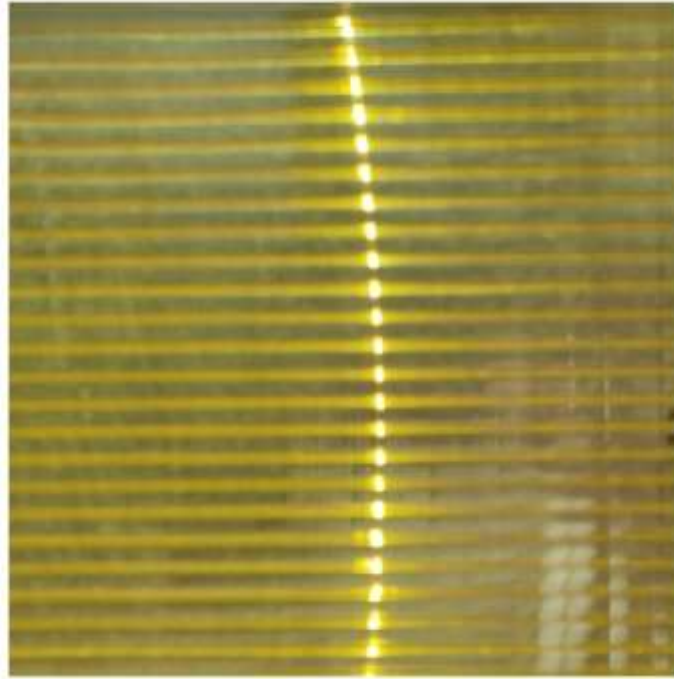

پلاستیک طرح چرم

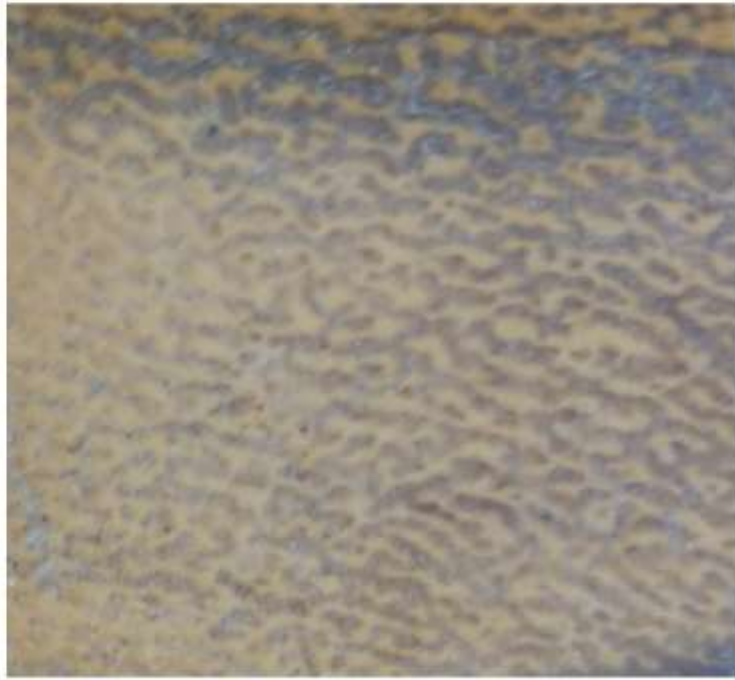

ديواره سطل جير (دلو)



رسوبات داخل سطح آب



ادامہ رسوبات داخل سطح آب



آهننگ زنگ زده



نوعی دیگر از آهن زنگ زده



سیمانی که رنگش ریخته



گلدان سنگی-سیمانی



سنگ ناسناس

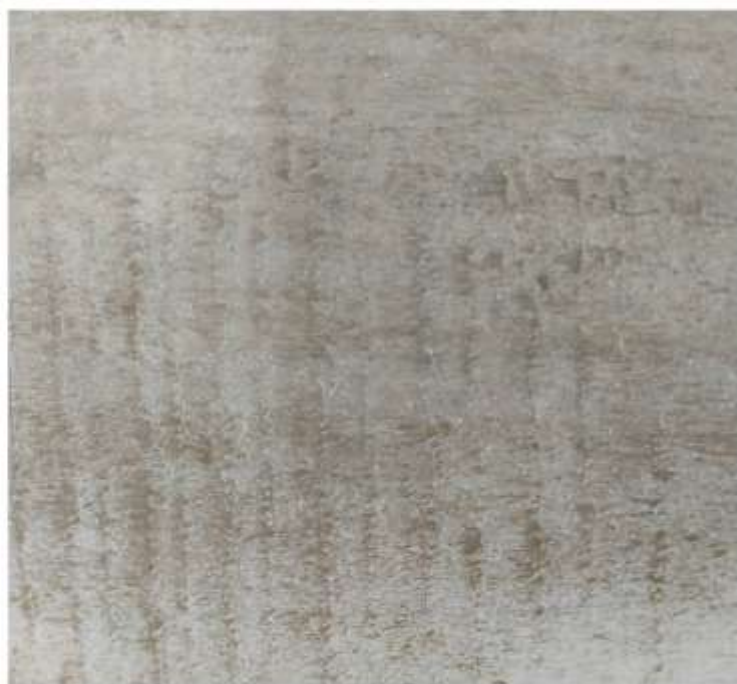

سنگ ناشناسی ۴



يونوليت



سنگ گانی بنتونیت



سنگ غیر مرمر شبیه مرمر



چون



خطا ۴.۵

بافت بعدی یافت نشد.

● برای یافتن بافت بیشتر اطرافتون رو نگاه کنید.

● تا تمرین بعدی صبر کنید.

با سپاس.

عکاسی با نسبت طلایی

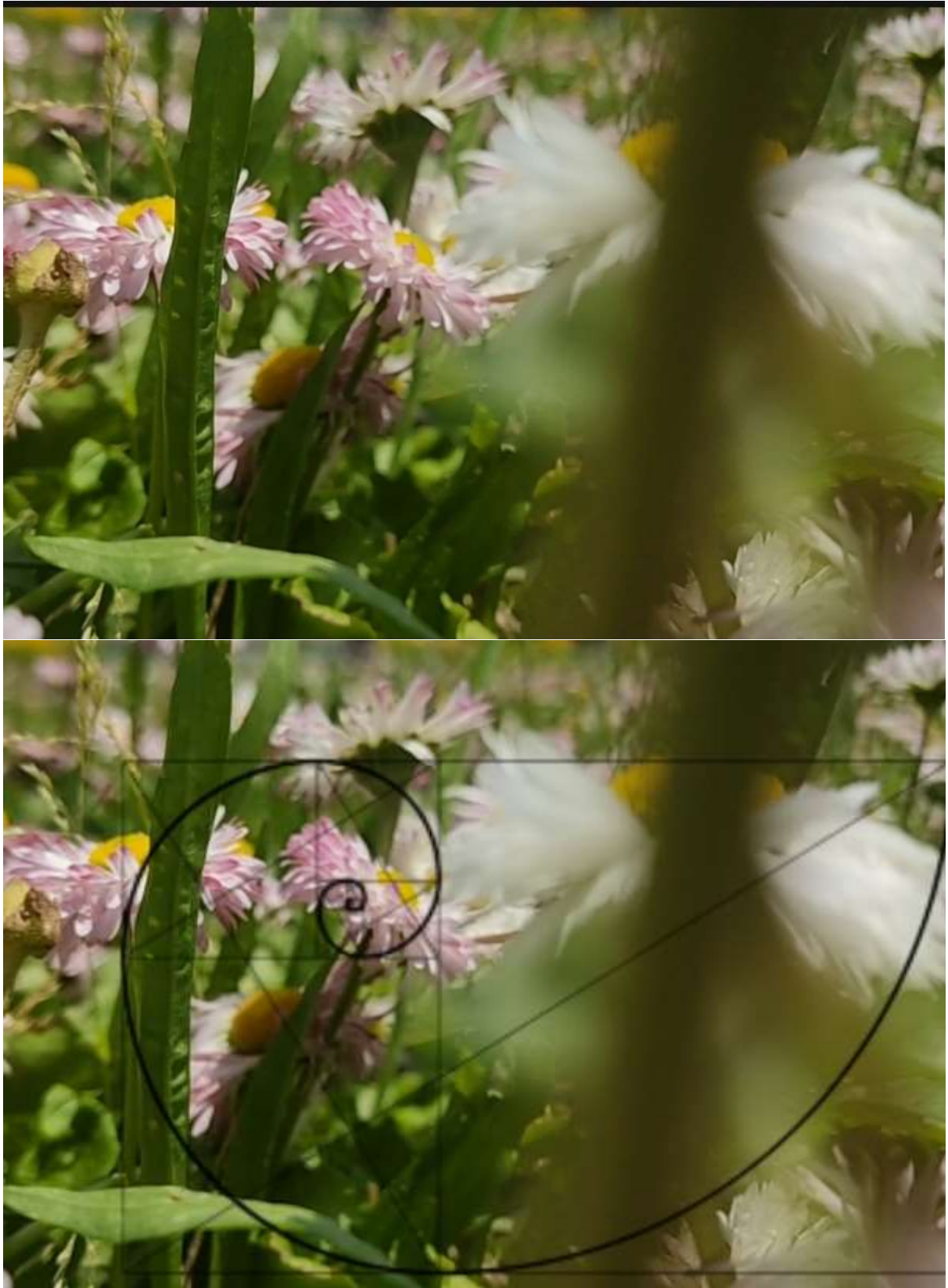



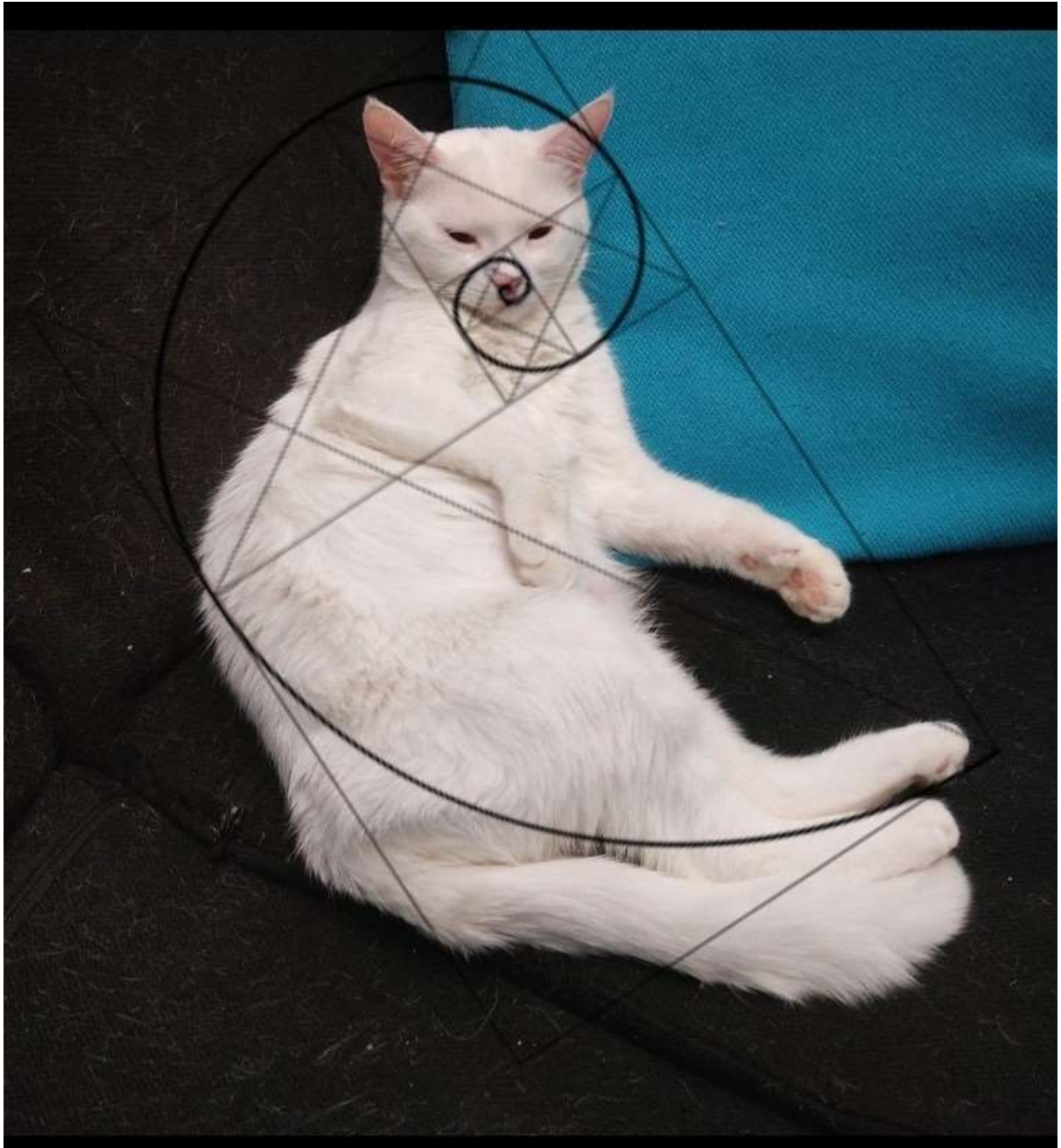



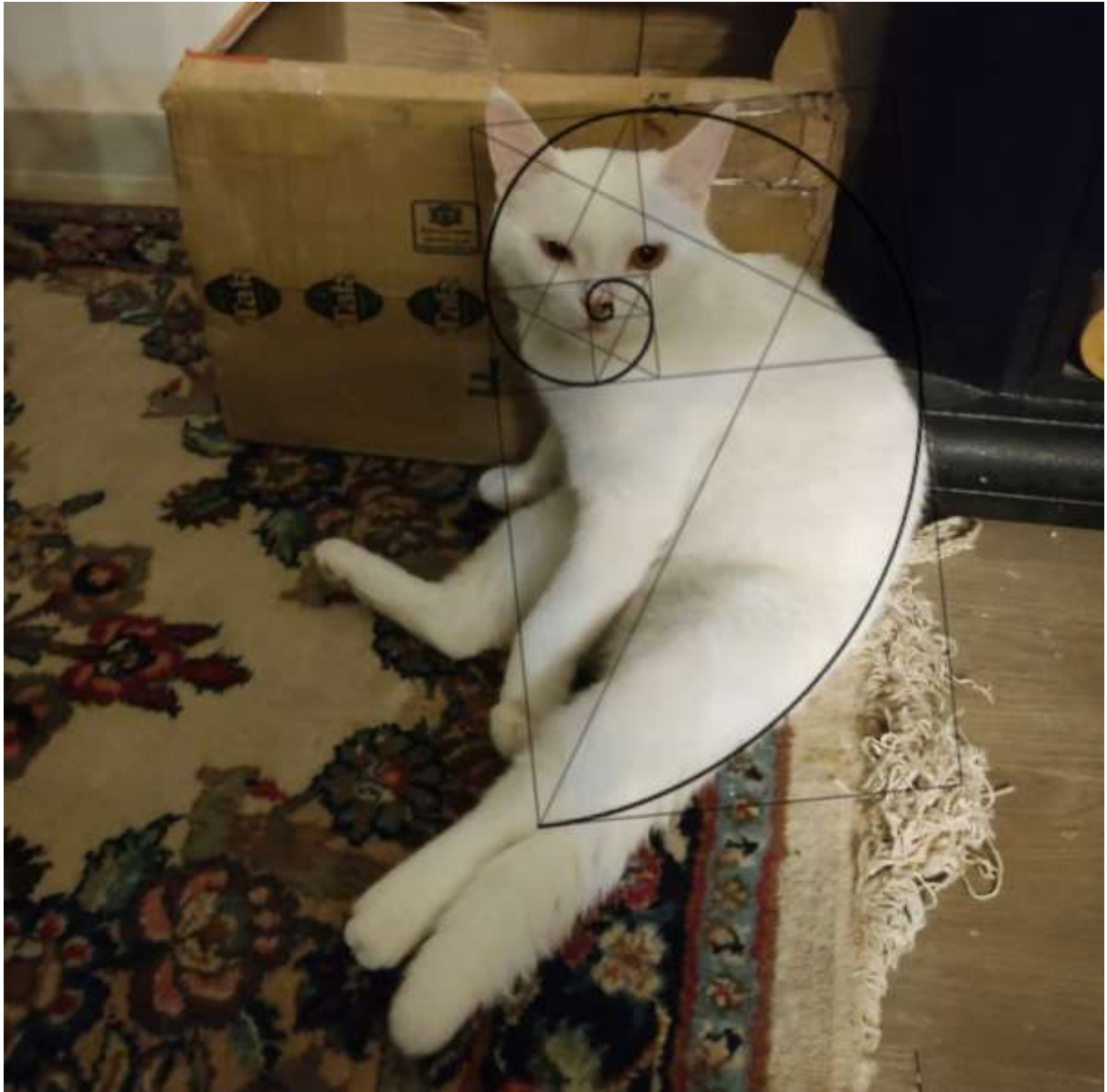







برای پی بردن به ترکیب بندی آثار، کانون تصویر و عناصر و

اشکال اولیه بکار رفته در هر اثر را شناسایی می کنیم.

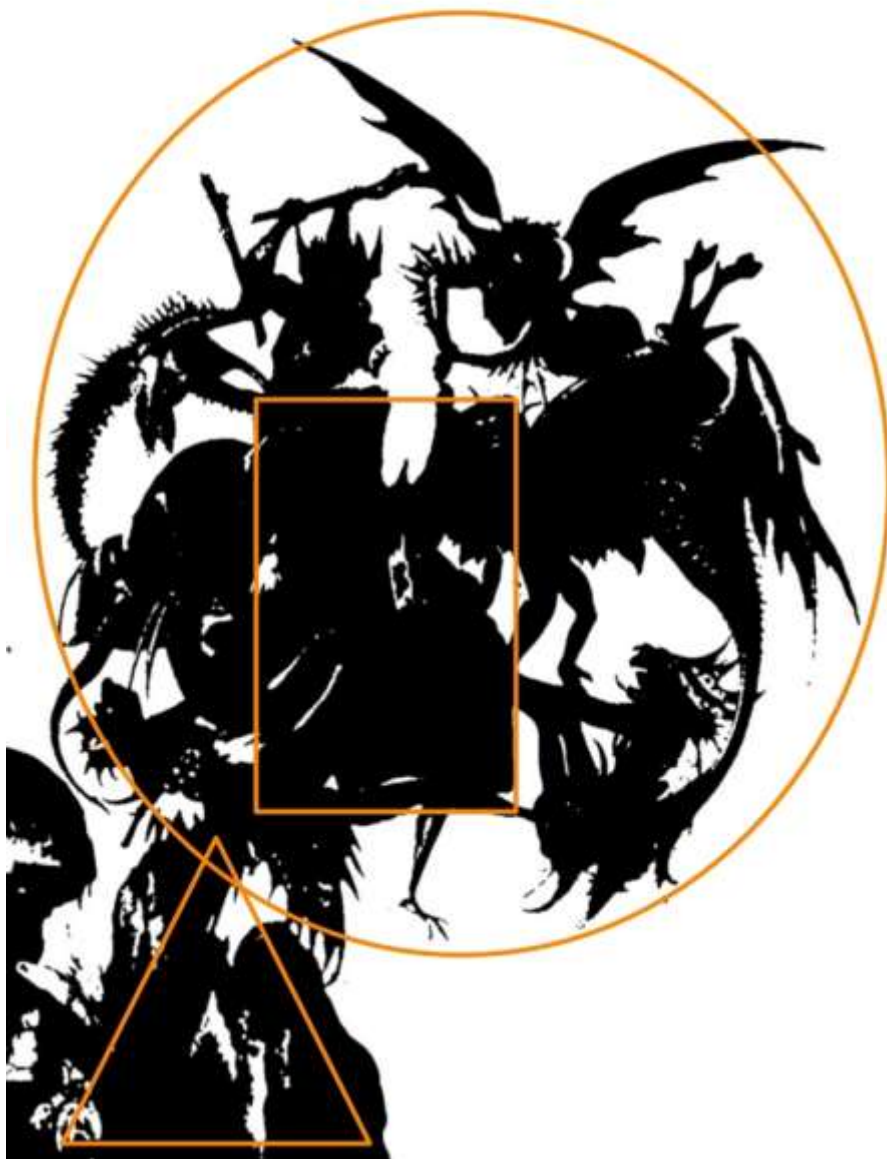

اثر اصلی



شناسایی اشکال اولیه در اثر و
یافتن کانون تصویر

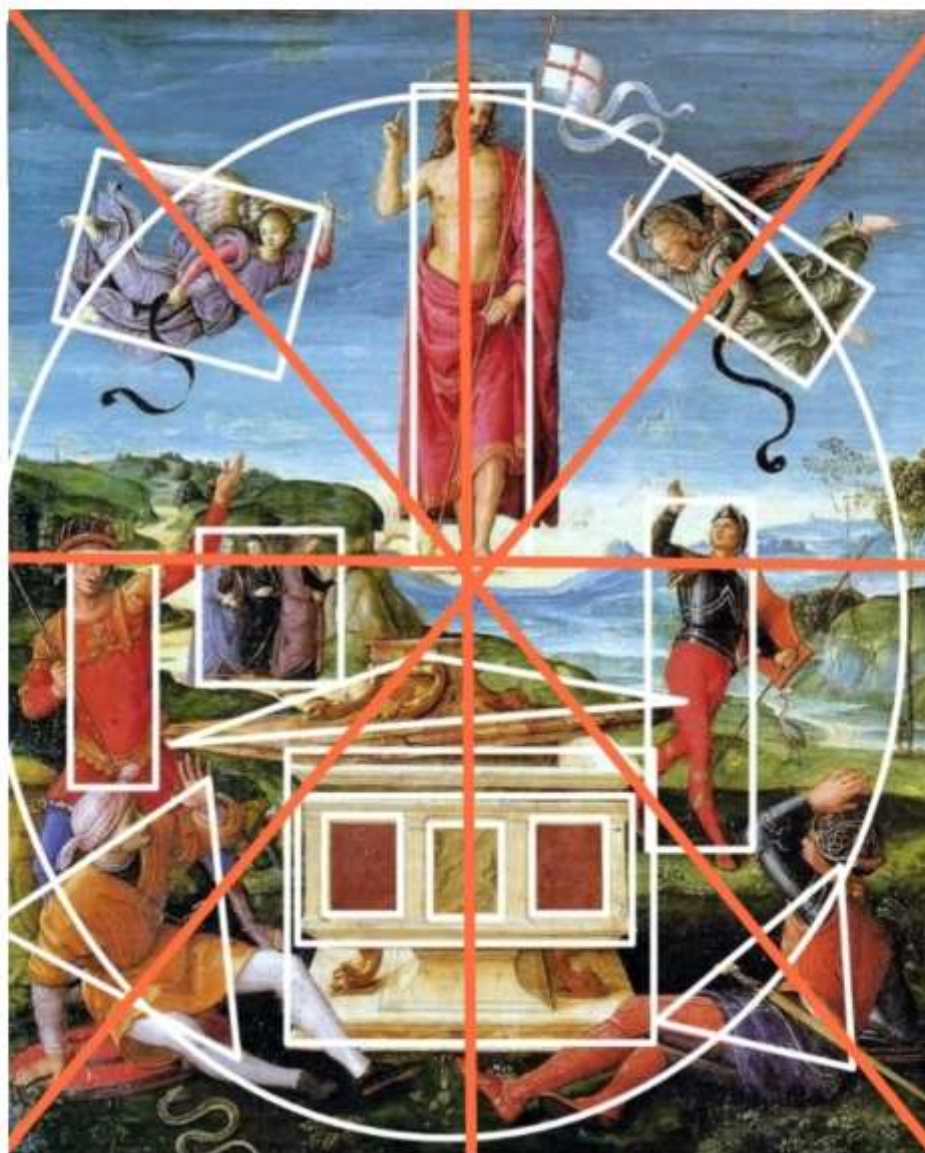

شناسایی اشکال اولیه در اثر

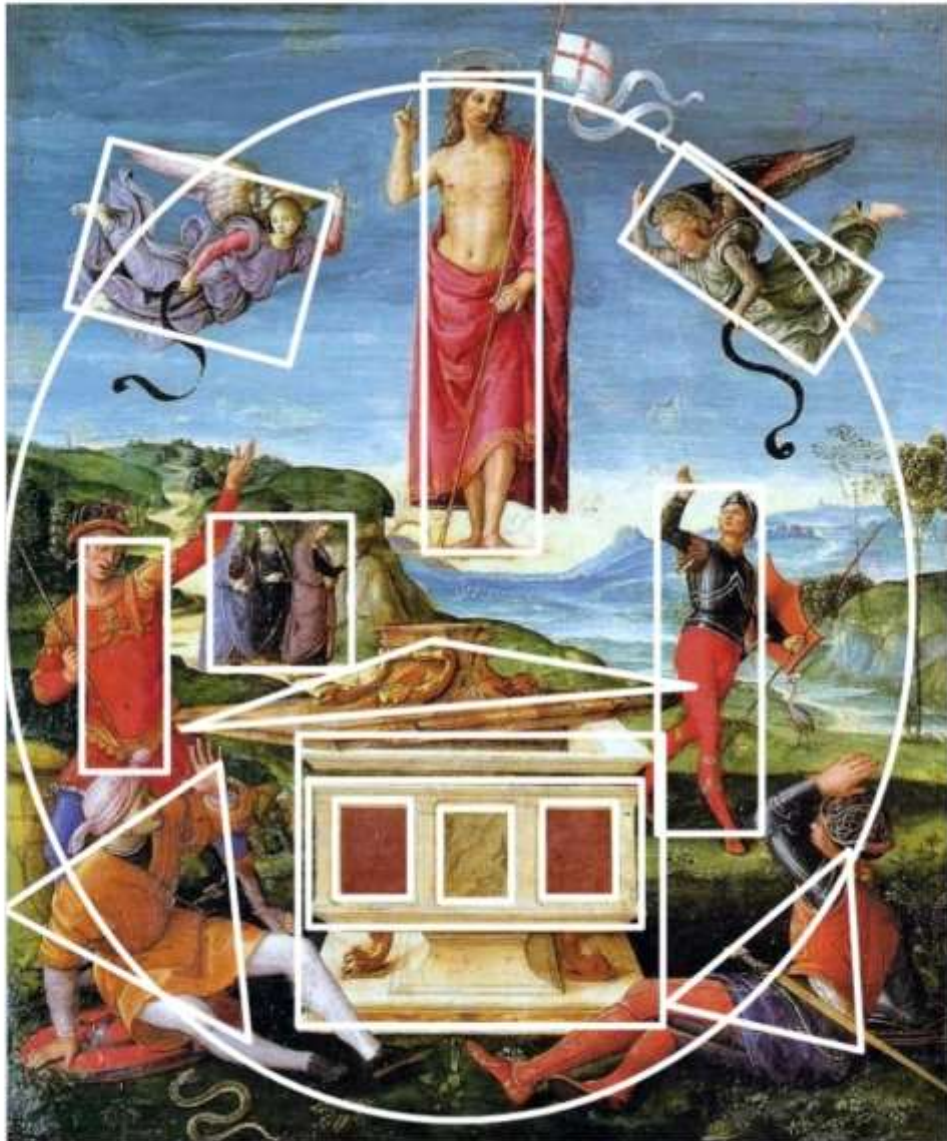

اثر اصل



كانون
تصوير



عناصر
تصوير

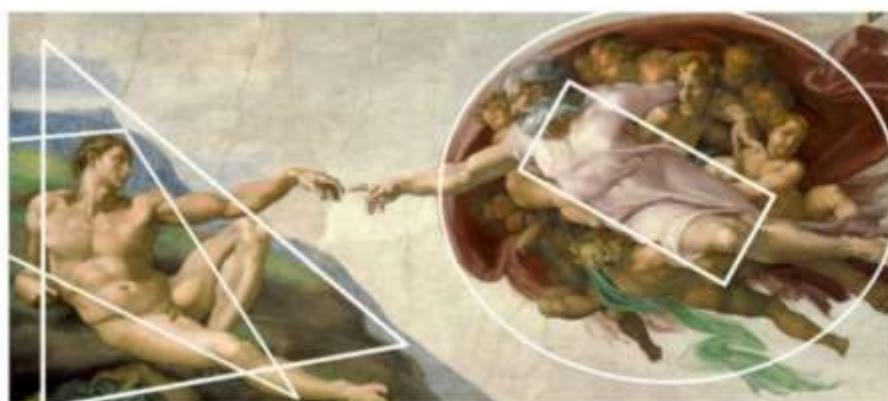

اثر اصلی



كانون تصوير



شناسایی عناصر و اشکال اولیه



ایجاد حجم

پارویدنا متخیبندی



ایجاد حجم با
تغییر درجه و اندازه



ایجاد حجم با روی هم اندازی
(و شفاف کردن)



ایجاد حجم با
پرسپکتیو



ایجاد حجم با
سایه



ایجاد عمق با بافت



ایجاد عمق با تغییر تدریجی رنگ پس
زمینه

(گرادینت)



ایجاد عمق با تغییر تدریجی رنگ
پس زمینه و بافت



ایجاد حجم با
شفاف کردن

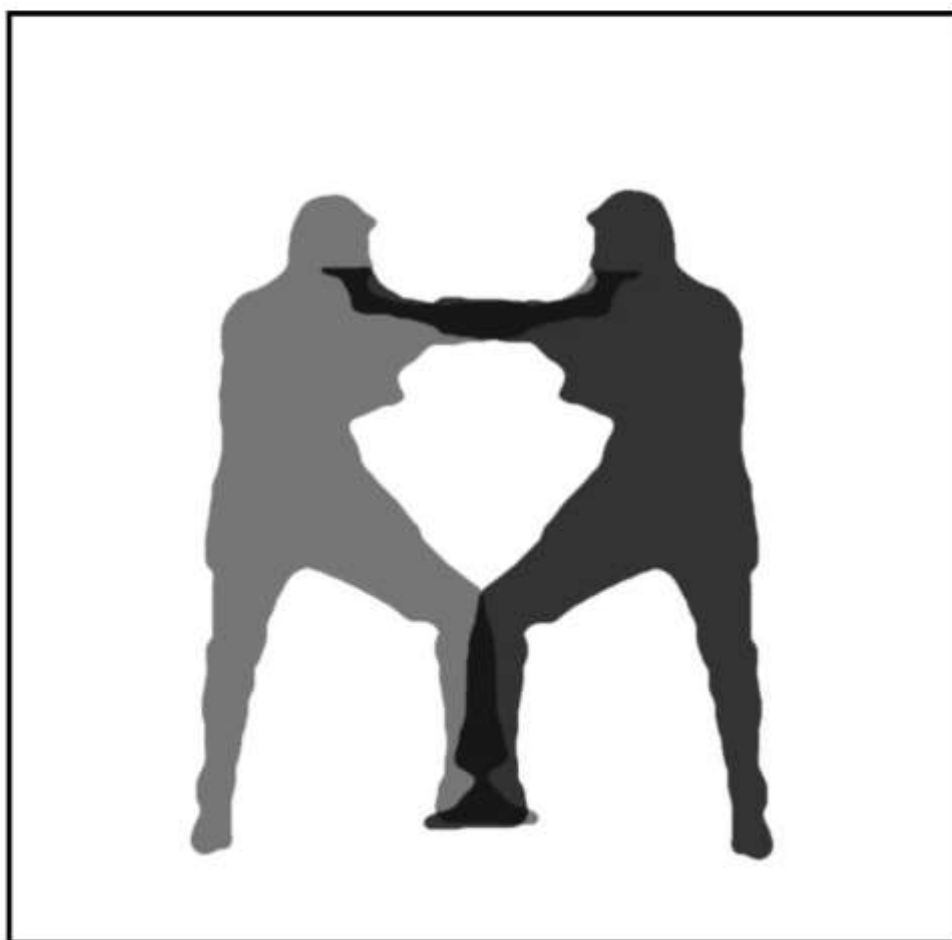

ایجاد حجم با
سایه و تغییر اندازه



ایجاد بعد و حجم با فضای نوسان دار

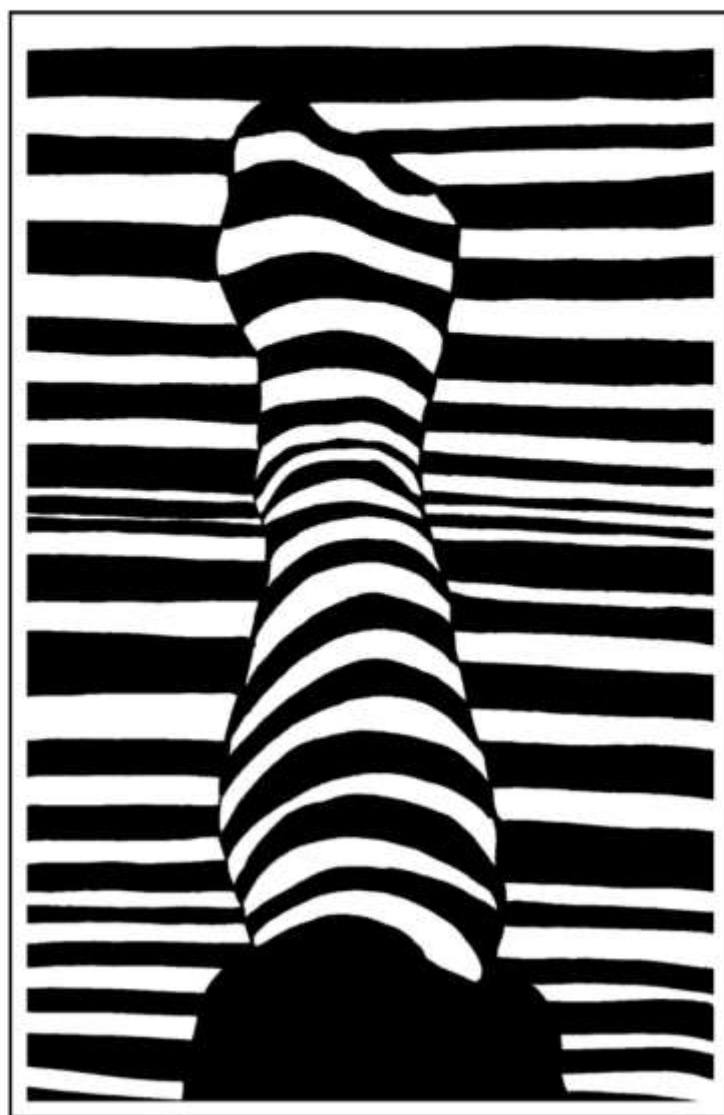

رسم طرح سه بعدی

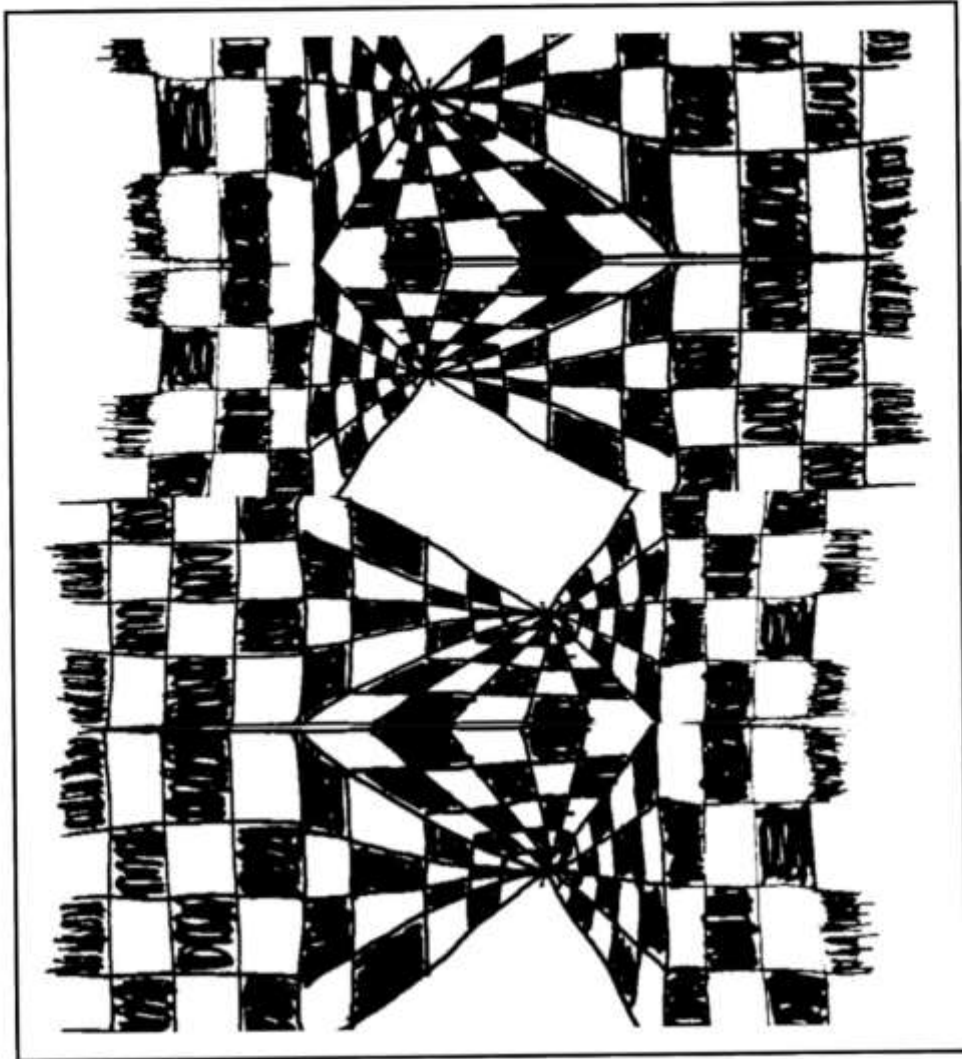

ابر واحد با فضای نوسان دار

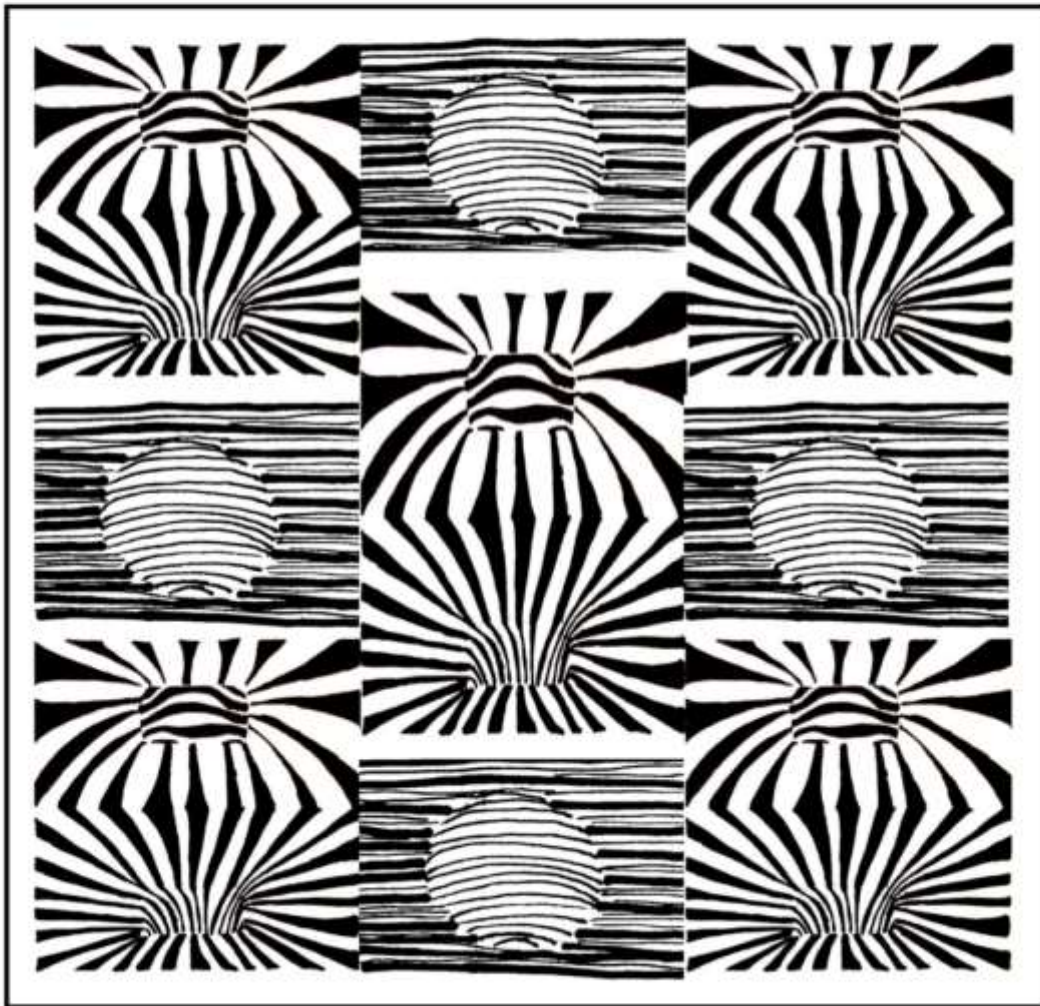

أنواع

تربیب



بندی

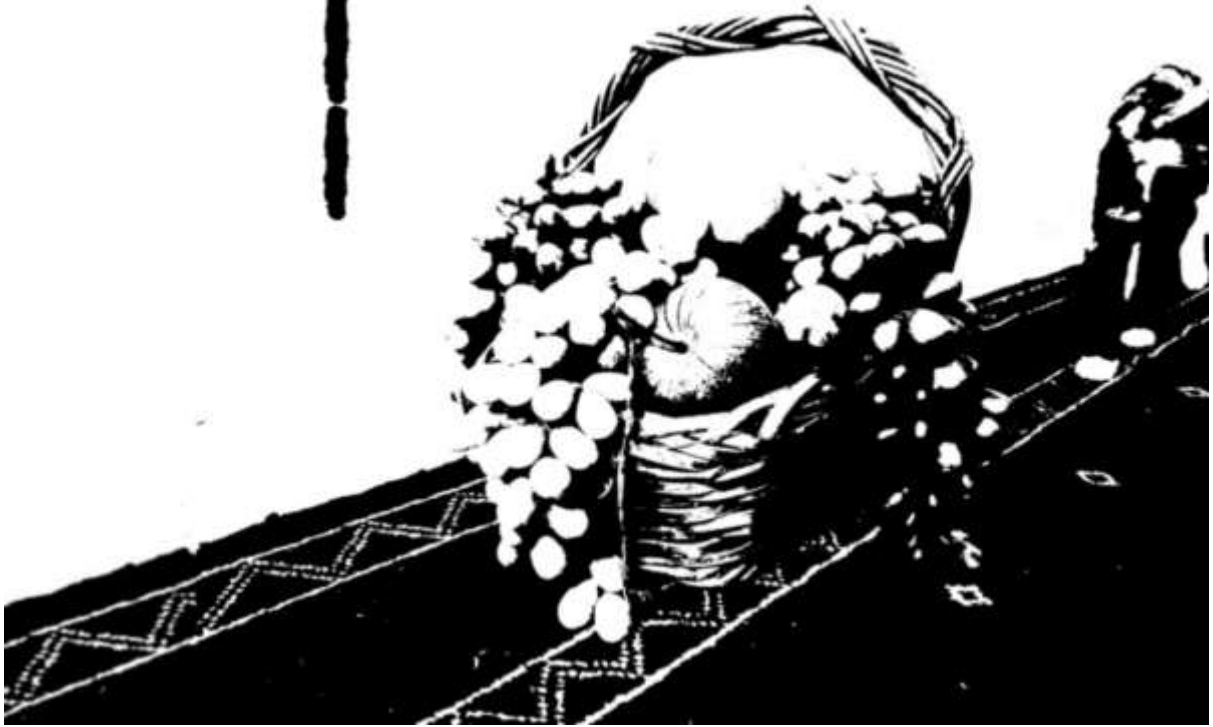

«قرینه»

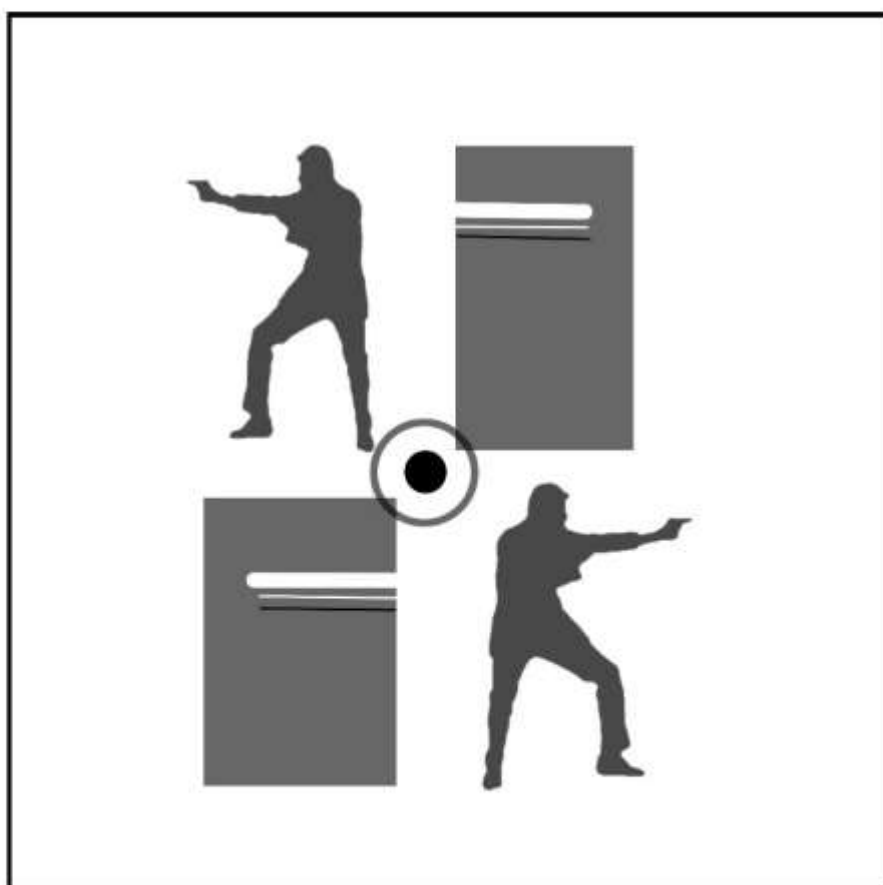

«متمرکز»

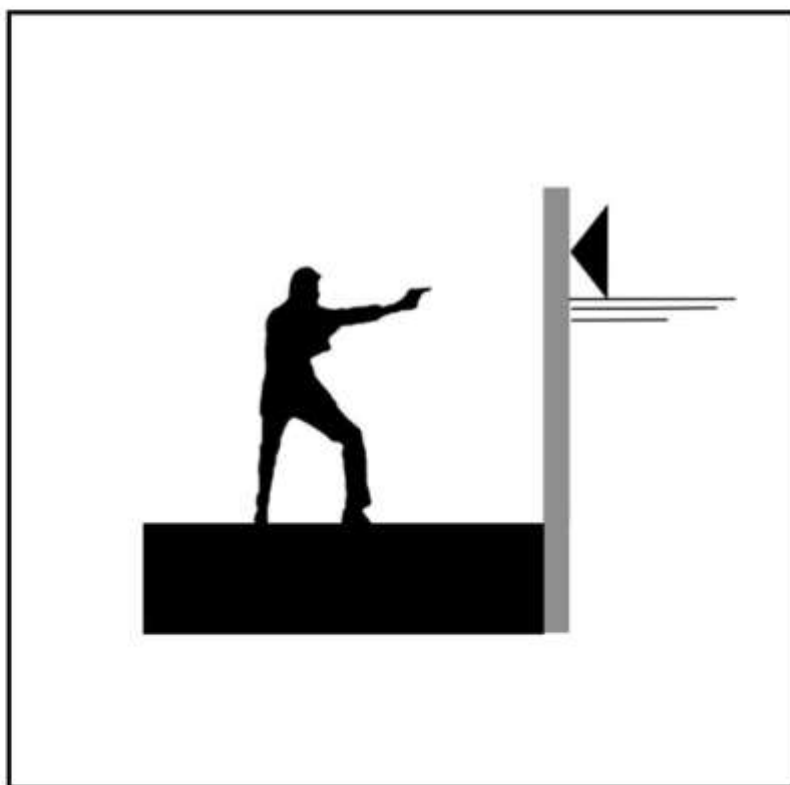

«غیر متمرکز»

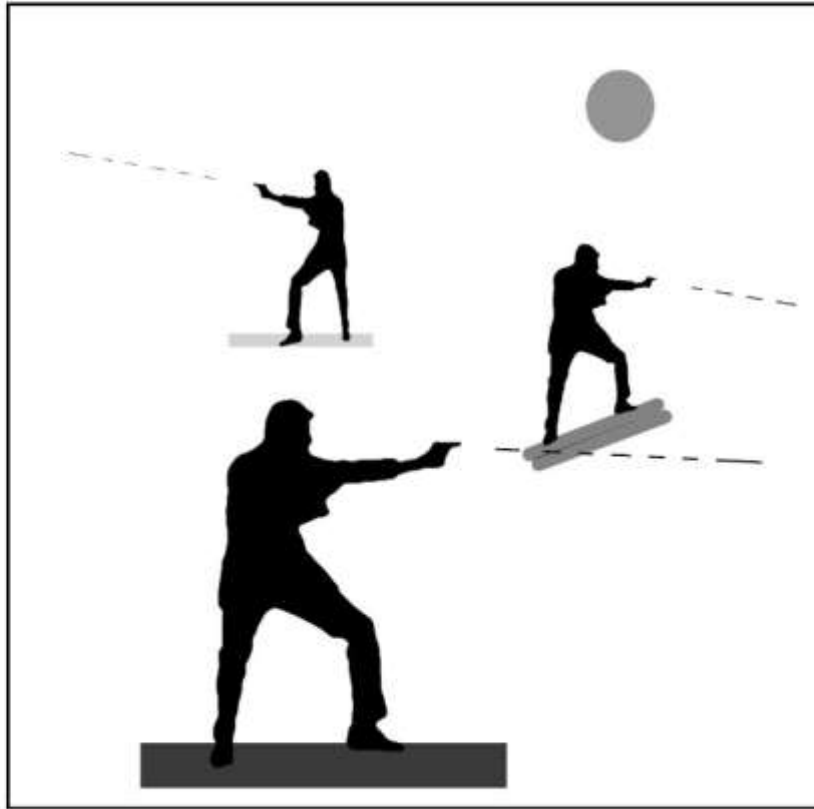

ترکیب بندی عمودی

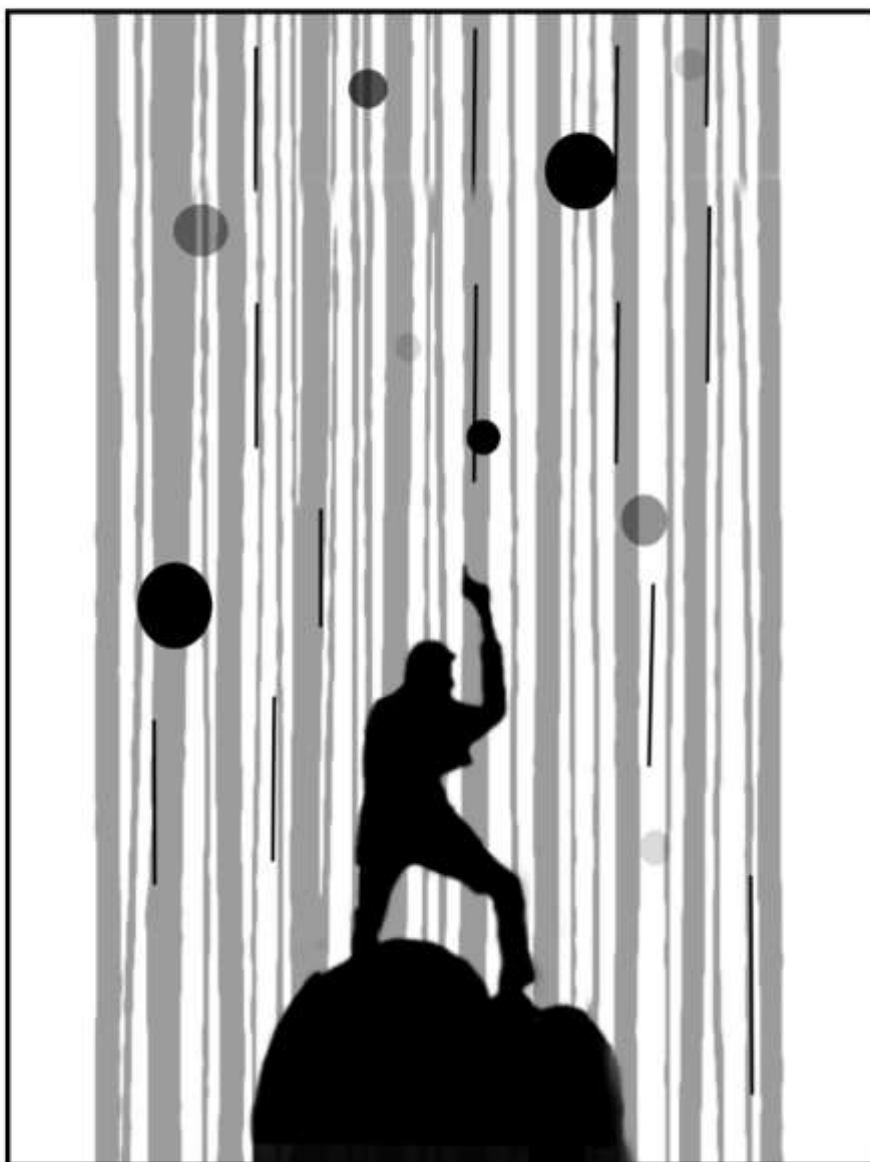

«اققى»

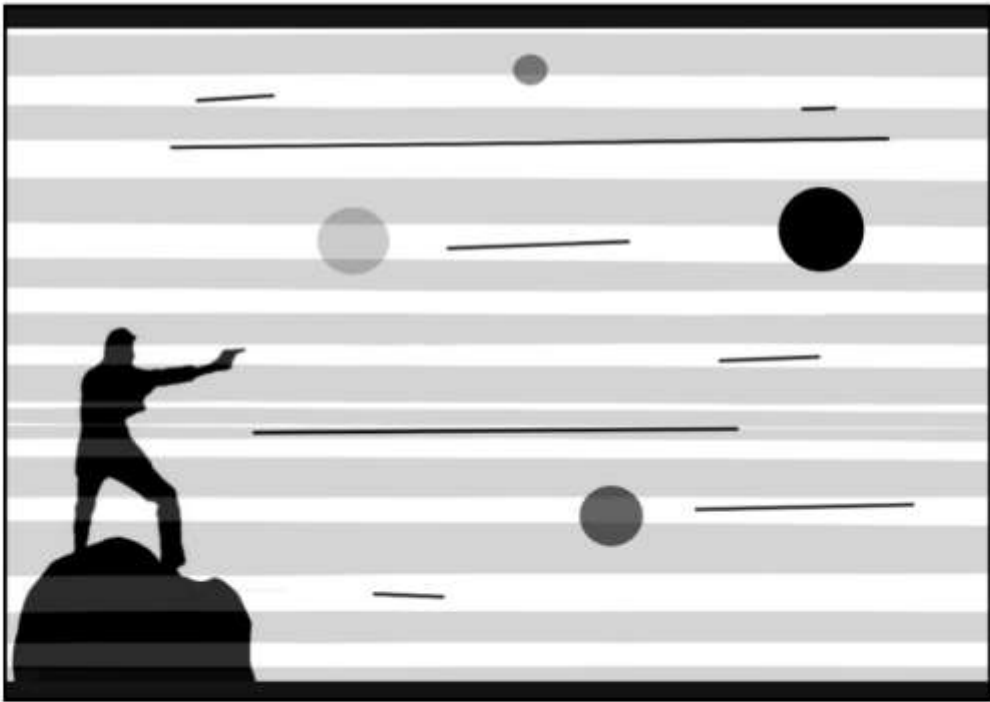

«متقاطع»

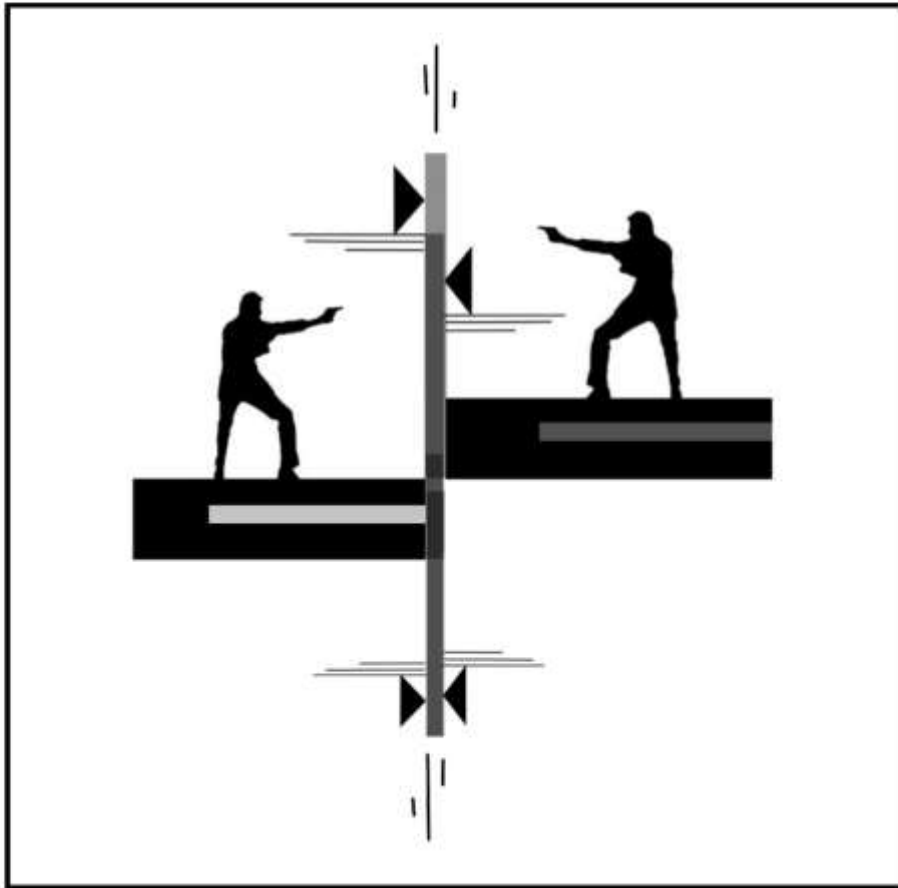

«ال»
-

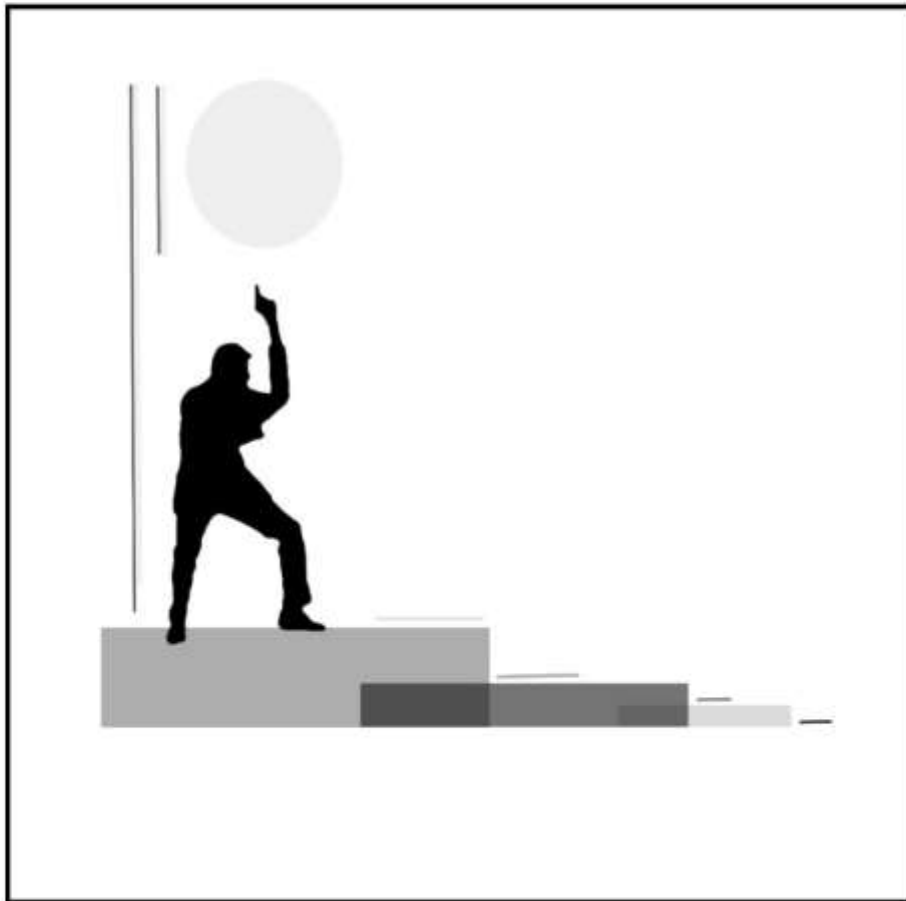

ترکیب بندی اس

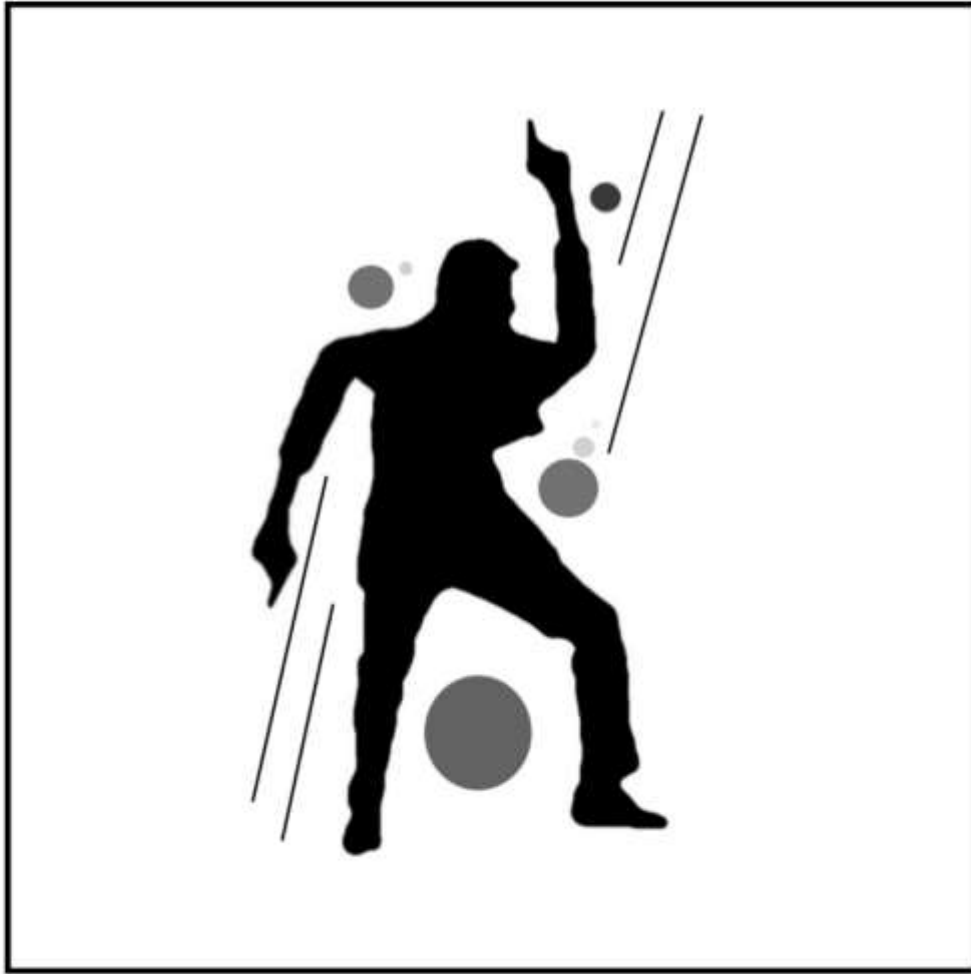

ترکیب بندی اس



ترکیب بندی مثلثی

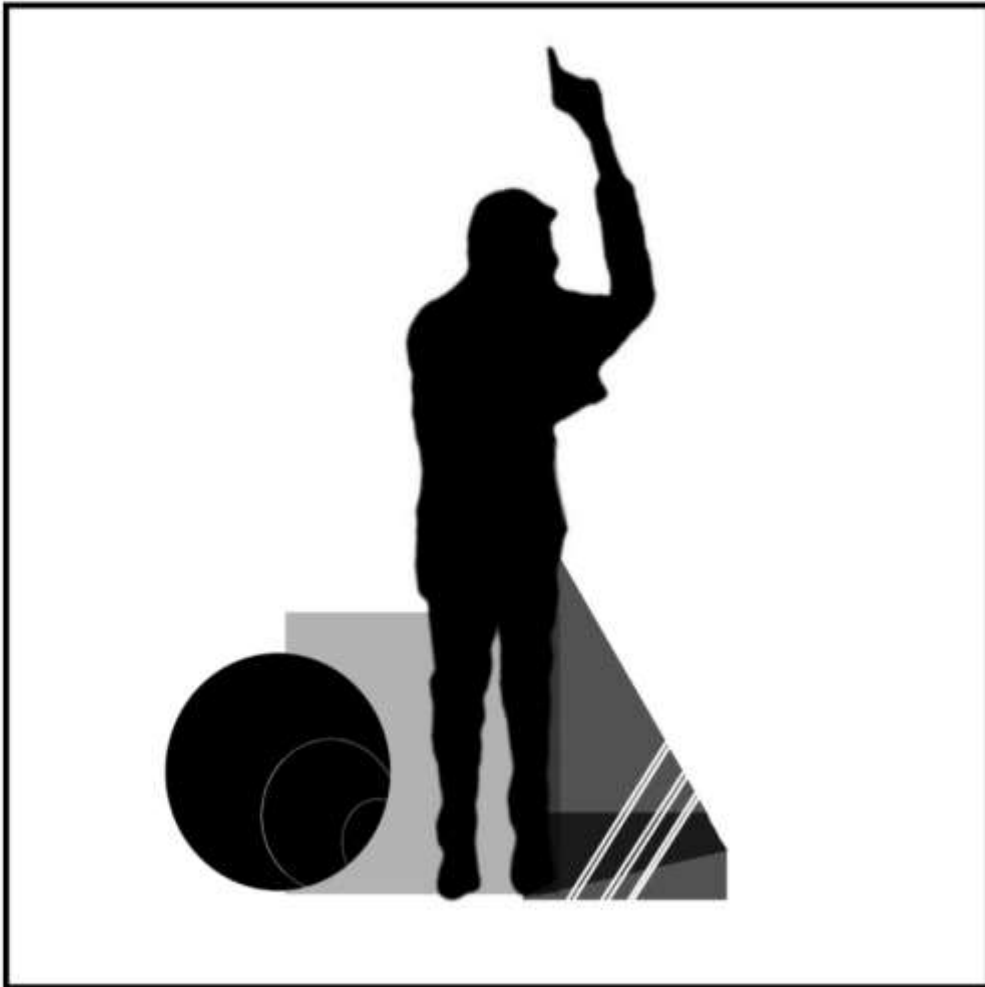

«مورب»

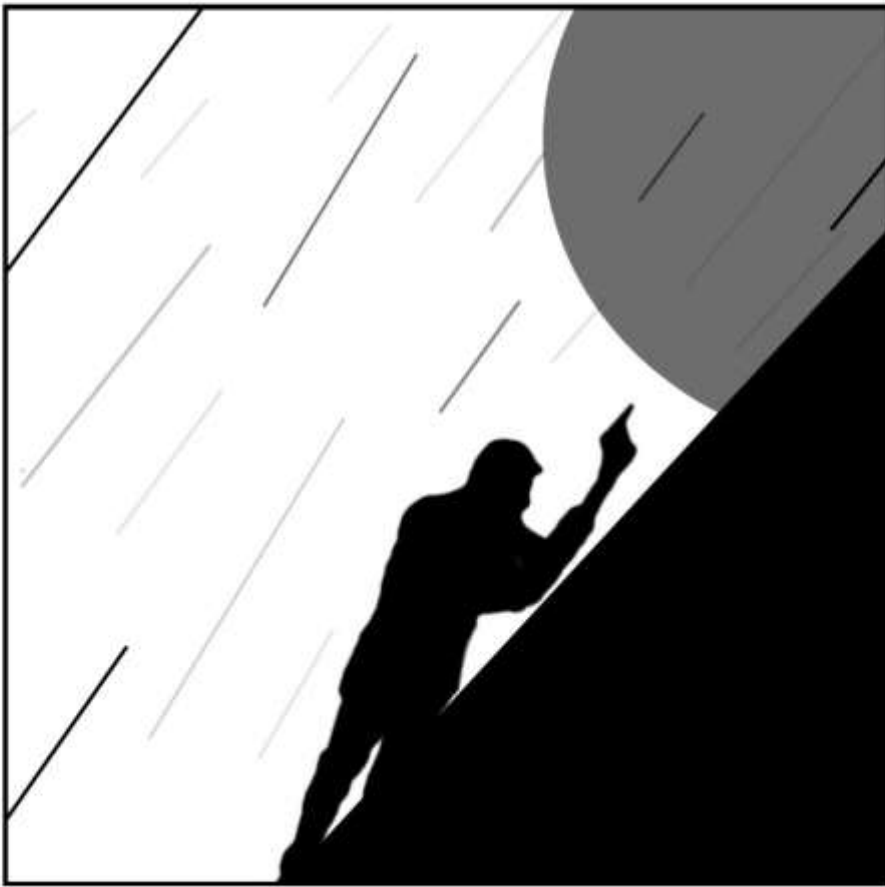

«دایره ای»



«مارپیچ»



زَبَانِ تَصْوِيرِ

بِكِ

«استاد کامران»
دانشگاه خوارزمی



«پایان»

تیرماه سال هزار و چهارصد